

3.3 V 100/133 MHz Differential 1:8 HCSL- Compatible Push-Pull Clock ZDB/Fanout Buffer for PCIe®

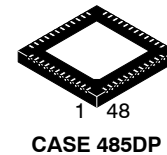

CASE 485DP

NB3W800L

Description

The NB3W800L is a low-power 8-output differential buffer that meets all the performance requirements of the DB800ZL specification. The NB3W800L is capable of distributing the reference clocks for Intel® QuickPath Interconnect (Intel QPI and UPI), PCIe Gen1/Gen2/Gen3/Gen4, SAS, SATA, and Intel Scalable Memory Interconnect (Intel SMI) applications. A fixed, internal feedback path maintains low drift for critical QPI applications.

Features

- 8 Differential Clock Output Pairs @ 0.7 V
- Low-power NMOS Push-pull HCSL Compatible Outputs
- Cycle-to-cycle Jitter <50 ps
- Output-to-output Skew <50 ps
- Input-to-output Delay Variation <100 ps
- PCIe Phase Jitter: Gen3 <1.0 ps, Gen4 <0.5 ps RMS
- QPI 9.6GT/s 12UI Phase Jitter <0.2 ps RMS
- Pseudo-External Fixed Feedback for Lowest Input-to-Output Delay
- Individual OE Control; Hardware Control of Each Output
- PLL Configurable for PLL Mode or Bypass Mode (Fanout Operation)
- 100 MHz or 133 MHz PLL Mode Operation; Supports PCIe, QPI and UPI Applications
- Selectable PLL Bandwidth; Minimizes Jitter Peaking in Downstream PLL's
- SMBus Programmable Configurations
- Spread Spectrum Compatible; Tracks Input Clock Spreading for Low EMI
- These are Pb-Free Devices

MARKING DIAGRAM

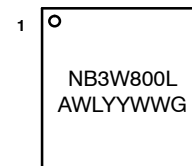

NB3W800L = Specific Device Code
 A = Assembly Location
 WL = Wafer Lot
 YY = Year
 WW = Work Week
 G = Pb-Free Package

ORDERING INFORMATION

Device	Package	Shipping*
NB3W800LMNTXG	QFN48 (Pb-Free)	2500 / Tape & Reel†

DISCONTINUED (Note 1)

NB3W800LMNG	QFN48 (Pb-Free)	490 / Tray
-------------	--------------------	------------

*Pin 1 in upper left corner of Tape and Reel

†For information on tape and reel specifications, including part orientation and tape sizes, please refer to our Tape and Reel Packaging Specifications Brochure, BRD8011/D.

1. **DISCONTINUED:** This device is not recommended for new design. Please contact your **onsemi** representative for information. The most current information on this device may be available on www.onsemi.com.

NB3W800L

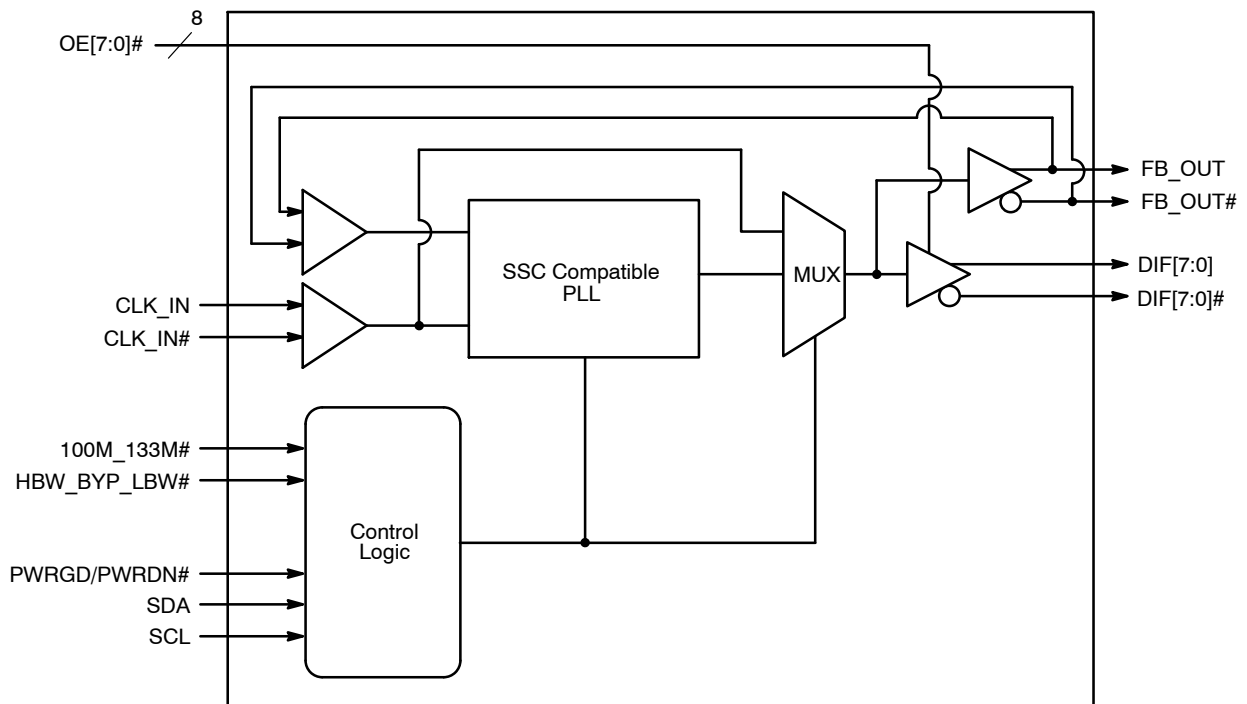

Figure 1. Simplified Block Diagram

Table 1. OE AND POWER PIN TABLE

Inputs		OE# Hardware Pins & Control Register Bits			Outputs	PLL State
PWRGD/ PWRDN#	CLK_IN/ CLK_IN#	SMBUS Enable Bit	OE# Pin	DIF/DIF# [7:0]	FB_OUT/ FB_OUT#	
0	X	X	X	Hi-Z	Hi-Z	OFF
1	Running	0	X	Hi-Z	Running	ON
		1	0	Running	Running	ON
		1	1	Hi-Z	Running	ON

Table 2. FUNCTIONALITY AT POWER-UP (PLL MODE)

100M_133M#	CLK_IN MHz	DIF(7:0)
1	100.00	CLK_IN
0	133.33	CLK_IN

Table 3. POWER CONNECTIONS

Pin Number		Description
VDD	GND	
44	49	Analog PLL
3	2	Analog Input
10, 15, 19, 27, 34, 38, 42	49	DIF clocks

Table 4. SMBus ADDRESS

Address	+ Read/Write bit
D8	R

Table 5. PLL OPERATING MODE READBACK TABLE

HBW_BYP_LBW#	Byte0, bit 7	Byte 0, bit 6
Low (Low BW)	0	0
Mid (Bypass)	0	1
High (High BW)	1	1

Table 6. TRI-LEVEL INPUT THRESHOLDS

Level	Voltage
Low	<0.8 V
Mid	1.2 < Vin < 1.8 V
High	Vin > 2.2 V

Table 7. PLL OPERATING MODE

HBW_BYP_LBW#	Mode
Low	PLL Lo BW
Mid	Bypass
High	PLL Hi BW

NOTE: PLL is OFF in Bypass Mode

NB3W800L

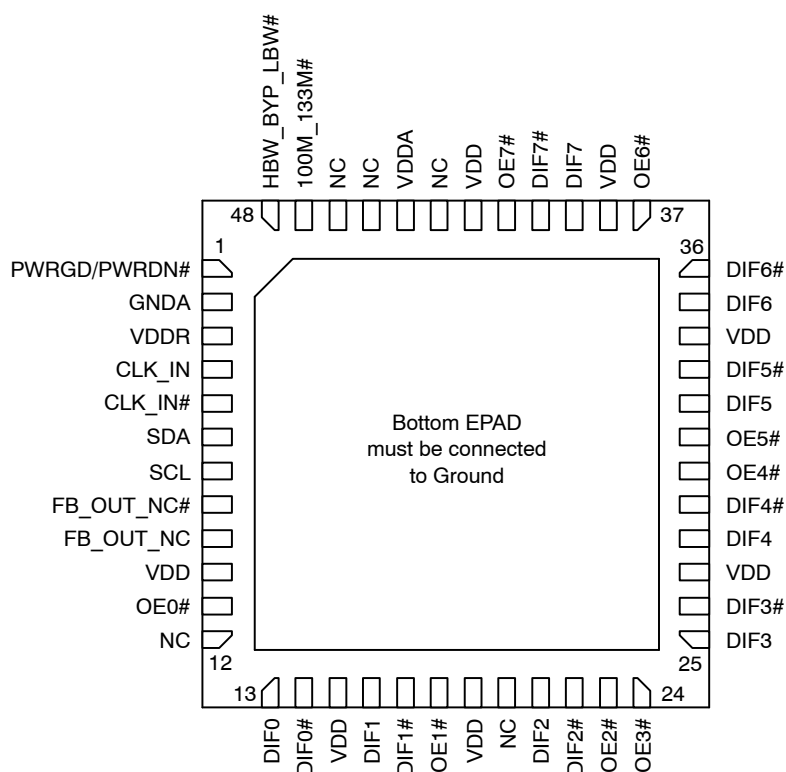

Figure 2. Pin Configuration

Table 8. PIN DESCRIPTIONS

Pin #	Pin Name	Type	Description
1	PWRGD/PWRDN#	IN	3.3 V Input notifies device to sample latched inputs and start up on first high assertion, or exit Power Down Mode on subsequent assertions. Low enters Power Down Mode.
2	GNDA	GND	Ground for Input Receiver and PLL Core
3	VDDR	PWR	3.3 V power for differential input clock (receiver). This VDD should be treated as an analog power rail and filtered appropriately.
4	CLK_IN	IN	0.7 V Differential true input
5	CLK_IN#	IN	0.7 V Differential complementary Input
6	SDA	I/O	Data pin of SMBus circuitry
7	SCL	IN	Clock pin of SMBus circuitry
8	FB_OUT_NC#	OUT	Complementary half of differential feedback output provides feedback signal to the PLL for synchronization with input clock to eliminate phase error. This pin should NOT be connected on the circuit board; the feedback is internal to the package.
9	FB_OUT_NC	OUT	True half of differential feedback output provides feedback signal to the PLL for synchronization with the input clock to eliminate phase error. This pin should NOT be connected on the circuit board; the feedback is internal to the package.
10	VDD	PWR	Power supply, nominal 3.3 V
11	OE0#	IN	Active low input for enabling DIF pair 0. This pin has an internal pull-down. 1 = disable outputs, 0 = enable outputs
12	NC	N/A	No Connection.
13	DIF0	OUT	0.7 V differential true clock output
14	DIF0#	OUT	0.7 V differential complementary clock output
15	VDD	PWR	Power supply, nominal 3.3 V
16	DIF1	OUT	0.7 V differential true clock output

NB3W800L

Table 8. PIN DESCRIPTIONS

Pin #	Pin Name	Type	Description
17	DIF1#	OUT	0.7 V differential complementary clock output
18	OE1#	IN	Active low input for enabling DIF pair 1. This pin has an internal pull-down. 1 = disable outputs, 0 = enable outputs
19	VDD	PWR	Power supply, nominal 3.3 V
20	NC	N/A	No Connection.
21	DIF2	OUT	0.7 V differential true clock output
22	DIF2#	OUT	0.7 V differential complementary clock output
23	OE2#	IN	Active low input for enabling DIF pair 2. This pin has an internal pull-down. 1 = disable outputs, 0 = enable outputs
24	OE3#	IN	Active low input for enabling DIF pair 3. This pin has an internal pull-down. 1 = disable outputs, 0 = enable outputs
25	DIF3	OUT	0.7 V differential true clock output
26	DIF3#	OUT	0.7 V differential complementary clock output
27	VDD	PWR	Power supply, nominal 3.3 V
28	DIF4	OUT	0.7 V differential true clock output
29	DIF4#	OUT	0.7 V differential complementary clock output
30	OE4#	IN	Active low input for enabling DIF pair 4. This pin has an internal pull-down. 1 = disable outputs, 0 = enable outputs
31	OE5#	IN	Active low input for enabling DIF pair 5. This pin has an internal pull-down. 1 = disable outputs, 0 = enable outputs
32	DIF5	OUT	0.7 V differential true clock output
33	DIF5#	OUT	0.7 V differential complementary clock output
34	VDD	PWR	Power supply, nominal 3.3 V
35	DIF6	OUT	0.7 V differential true clock output
36	DIF6#	OUT	0.7 V differential complementary clock output
37	OE6#	IN	Active low input for enabling DIF pair 6. This pin has an internal pull-down. 1 = disable outputs, 0 = enable outputs
38	VDD	PWR	Power supply, nominal 3.3 V
39	DIF7	OUT	0.7 V differential true clock output
40	DIF7#	OUT	0.7 V differential complementary clock output
41	OE7#	IN	Active low input for enabling DIF pair 7. This pin has an internal pull-down. 1 = disable outputs, 0 = enable outputs
42	VDD	PWR	Power supply, nominal 3.3 V
43	NC	N/A	No Connection.
44	VDDA	PWR	3.3 V power for the PLL core.
45	NC	N/A	No Connection.
46	NC	N/A	No Connection.
47	100M_133M#	IN	3.3 V Input to select operating frequency. See Functionality Table for Definition
48	HBW_BYP_LBW#	IN	Trilevel input to select High BW, Bypass or Low BW mode. See PLL Operating Mode Table for Details.
49	GND	PWR	EPAD, must be connected to Ground

NB3W800L

Table 9. ABSOLUTE MAXIMUM RATINGS

Symbol	Parameter	Conditions	Min	Typ	Max	Units
VDD, VDDA	3.3 V Supply Voltage (Notes 2, 3)	VDD for core logic and PLL			4.6	V
V _{IL}	Input Low Voltage (Note 2)		GND-0.5			V
V _{IH}	Input High Voltage (Note 2)	Except for SMBus interface			V _{DD} + 0.5	V
V _{IHSMB}	Input High Voltage (Note 2)	SMBus clock and data pins			5.5	V
T _s	Storage Temperature (Note 2)		-65		150	°C
T _j	Junction Temperature (Note 2)				125	°C
ESD prot	Input ESD protection (Note 2)	Human Body Model	2000			V
θ _{JA}	Thermal Resistance, Junction-to-Ambient	Still air		17		°C/W
θ _{JC}	Thermal Resistance, Junction-to-Case			7		°C/W

Stresses exceeding those listed in the Maximum Ratings table may damage the device. If any of these limits are exceeded, device functionality should not be assumed, damage may occur and reliability may be affected.

- Guaranteed by design and characterization, not tested in production.
- Operation under these conditions is neither implied nor guaranteed.

Table 10. ELECTRICAL CHARACTERISTICS—CLOCK INPUT PARAMETERS (HCSL-COMPATIBLE)

(V_{DD} = V_{DDA} = 3.3 V ±5%, T_A = 0°C – 70°C), See Test Loads for Loading Conditions. (Note 6)

Symbol	Parameter	Conditions	Min	Typ	Max	Units
V _{IHCLK_IN}	Input High Voltage - CLK_IN (Note 4)	Differential inputs (single-ended measurement)	600	800	1150	mV
V _{ILCLK_IN}	Input Low Voltage - CLK_IN (Note 4)	Differential inputs (single-ended measurement)	V _{SS} - 300	0	300	mV
V _{COM}	Input Common Mode Voltage - CLK_IN (Note 4)	Common Mode Input Voltage (Single-ended measurement)	300		1000	mV
V _{SWING}	Input Amplitude - CLK_IN (Note 4)	Peak to Peak (differential)	300		1450	mV
dv/dt	Input Slew Rate - CLK_IN (Notes 4, 5)	Measured differentially	0.35		8	V/ns
I _{IN}	Input Leakage Current (Note 4)	V _{IN} = V _{DD} , V _{IN} = GND	-5		5	μA
d _{tin}	Input Duty Cycle (Note 4)	Measurement from differential waveform	45		55	%
J _{DIFIn}	Input Jitter - Cycle to Cycle (Note 4)	Differential Measurement			125	ps

Product parametric performance is indicated in the Electrical Characteristics for the listed test conditions, unless otherwise noted. Product performance may not be indicated by the Electrical Characteristics if operated under different conditions.

- Guaranteed by design and characterization, not tested in production.
- Slew rate measured through ±75 mV window centered around differential zero.
- Test configuration is; R_s = 27 Ω, 2 pF for 85 Ω transmission line.

NB3W800L

Table 11. ELECTRICAL CHARACTERISTICS – Input/Supply/Common Parameters

($V_{DD} = V_{DDA} = 3.3\text{ V} \pm 5\%$, $T_A = 0^\circ\text{C} - 70^\circ\text{C}$), See Test Loads for Loading Conditions. (Note 12)

Symbol	Parameter	Conditions	Min	Typ	Max	Units
V_{IH}	Input High Voltage (Note 7)	Single-ended inputs, except SMBus, low threshold and tri-level inputs	2		$V_{DD} + 0.3$	V
V_{IL}	Input Low Voltage (Note 7)	Single-ended inputs, except SMBus, low threshold and tri-level inputs	$GND - 0.3$		0.8	V
I_{IN}	Input Current (Note 7)	Single-ended inputs, $V_{IN} = GND$, $V_{IN} = V_{DD}$	-5		5	μA
I_{INP}		Single-ended inputs $V_{IN} = 0\text{ V}$; Inputs with internal pull-up resistors $V_{IN} = V_{DD}$; Inputs with internal pull-down resistors	-200		200	μA
F_{ibyp}	Input Frequency (Note 8)	$V_{DD} = 3.3\text{ V}$, Bypass mode	33		150	MHz
F_{ipll}		$V_{DD} = 3.3\text{ V}$, 100 MHz PLL mode	99	100.00	101	MHz
F_{ipll}		$V_{DD} = 3.3\text{ V}$, 133.33 MHz PLL mode	132.33	133.33	134.33	MHz
L_{pin}	Pin Inductance (Note 7)				7	nH
C_{IN}	Capacitance (Note 7)	Logic Inputs, except CLK_IN	1.5		4.5	pF
C_{INCLK_IN}		CLK_IN differential clock inputs (Note 10)	1.5		2.7	pF
C_{OUT}		Output pin capacitance			4.5	pF
f_{MODIN}	Input SS Modulation Frequency (Note 7)	Allowable Frequency (Triangular Modulation)	30		33	kHz
$t_{LATO\#}$	OE# Latency (Notes 7, 9)	DIF start after OE# assertion DIF stop after OE# deassertion	4		8	cycles
t_{DRVPD}	Tdrive_PD# (Notes 7, 9)	DIF output enable after PD# de-assertion			300	μs
t_F	Tfall (Notes 7, 8)	Fall time of control inputs			10	ns
t_R	Trise (Notes 7, 8)	Rise time of control inputs			10	ns
V_{ILSMB}	SMBus Input Low Voltage (Note 7)				0.8	V
V_{IHSMB}	SMBus Input High Voltage (Note 7)		2.1		V_{DDSMB}	V
V_{OLSMB}	SMBus Output Low Voltage (Note 7)	@ I_{PULLUP}			0.4	V
I_{PULLUP}	SMBus Sink Current (Note 7)	@ V_{OL}	4			mA
V_{DDSMB}	Nominal Bus Voltage (Note 7)	3 V to 5 V $\pm 10\%$	2.7		5.0	V
t_{RSMB}	SCL/SDA Rise Time (Note 7)	(Max $V_{IL} - 0.15$) to (Min $V_{IH} + 0.15$)			1000	ns
t_{FSMB}	SCL/SDA Fall Time (Note 7)	(Min $V_{IH} + 0.15$) to (Max $V_{IL} - 0.15$)			300	ns
f_{MAXSMB}	SMBus Operating Frequency (Notes 7, 11)	Maximum SMBus operating frequency			100	kHz

7. Guaranteed by design and characterization, not tested in production.

8. Control input must be monotonic from 20% to 80% of input swing.

9. Time from deassertion until outputs are $>200\text{ mV}$

10. CLK_IN input

11. The differential input clock must be running for the SMBus to be active

12. Test configuration is; $R_s = 27\ \Omega$, 2 pF for 85 Ω transmission line.

NB3W800L

Table 12. DIF 0.7 V AC TIMING CHARACTERISTICS (Non-Spread or –0.5% Spread Spectrum Mode)

($V_{DD} = V_{DDA} = 3.3 \text{ V} \pm 5\%$, $T_A = 0^\circ\text{C} - 70^\circ\text{C}$), See Test Loads for Loading Conditions.

Symbol	Parameter		CLK = 100 MHz, 133.33 MHz		Unit
			Min	Max	
Tstab (Note 33)	Clock Stabilization Time			1.8	ms
Laccuracy (Notes 16, 20, 28, 34)	Long Accuracy			100	ppm
Tabs (Notes 16, 17, 20)	Absolute Min/Max Host CLK Period	No Spread	9.94900 for 100 MHz	10.05100 for 100 MHz	ns
			7.44925 for 133 MHz	7.55075 for 133 MHz	
		–0.5% Spread	9.49900 for 100 MHz	10.10126 for 100 MHz	
			7.44925 for 133 MHz	7.58845 for 133 MHz	
Slew_rate (Notes 14, 16, 20)	DIFF OUT Slew_rate		1.0	4.0	V/ns
$\Delta\text{Trise} / \Delta\text{Tfall}$ (Notes 16, 20, 30)	Rise and Fall Time Variation			125	ps
Rise/Fall Matching (Notes 16, 20, 31, 32)				20	%
VHigh (Notes 16, 19, 22)	Voltage High (typ 0.70 Volts)		660	850	mV
VLow (Notes 16, 19, 23)	Voltage Low (typ 0.0 Volts)		–150	150	mV
Vmax (Note 19)	Maximum Voltage			1150	mV
Vcross absolute (Notes 13, 15, 16, 19, 26)	Absolute Crossing Point Voltages		250	550	mV
Vcross relative (Notes 16, 18, 19, 26)	Relative Crossing Point Voltages		Calc	Calc	
Total Δ Vcross (Notes 16, 19, 27)	Total Variation of Vcross Over All Edges			140	mV
Vovs (Notes 16, 19, 24)	Maximum Voltage (Overshoot)			Vhigh + 0.3	V
Vuds (Notes 16, 19, 25)	Maximum Voltage (Undershoot)			Vlow – 0.3	V

13. Measured at crossing point where the instantaneous voltage value of the rising edge of CLK equals the falling edge of CLK#.
14. Measurement taken from differential waveform on a component test board. The slew rate is measured from –150 mV to +150 mV on the differential waveform. Scope is set to average because the scope sample clock is making most of the dynamic wiggles along the clock edge. Only valid for Rising CLK_IN and Falling CLK_IN#. Signal must be monotonic through the Vol to Voh region for Trise and Tfall.
15. This measurement refers to the total variation from the lowest crossing point to the highest, regardless of which edge is crossing.
16. Test configuration is; $R_s = 27 \Omega$, 2 pF for 85 Ω transmission line.
17. The average period over any 1 μs period of time must be greater than the minimum and less than the maximum specified period.
18. Vcross(rel) Min and Max are derived using the following, Vcross(rel) Min = $0.250 + 0.5 (V_{\text{havg}} - 0.700)$, Vcross(rel) Max = $0.550 - 0.5 (0.700 - V_{\text{havg}})$
19. Measurement taken from Single Ended waveform.
20. Measurement taken from differential waveform. Bypass mode, input duty cycle = 50%.
21. Unless otherwise noted, all specifications in this table apply to all processor frequencies.
22. VHigh is defined as the statistical average High value as obtained by using the Oscilloscope VHigh Math function.
23. VLow is defined as the statistical average Low value as obtained by using the Oscilloscope VLow Math function.
24. Overshoot is defined as the absolute value of the maximum voltage.
25. Undershoot is defined as the absolute value of the minimum voltage.
26. The crossing point must meet the absolute and relative crossing point specifications simultaneously.
27. Δ Vcross is defined as the total variation of all crossing voltages of Rising DIF and Falling DIF#. This is the maximum allowed variance in Vcross for any particular system.
28. Using frequency counter with the measurement interval equal or greater than 0.15 s, target frequencies are 100,000,000 Hz, 133,333,333 Hz.
29. Using frequency counter with the measurement interval equal or greater than 0.15 s, target frequencies are 99,750,00 Hz, 133,000,000 Hz.
30. Measured with oscilloscope, averaging off, using min max statistics. Variation is the delta between min and max.
31. Measured with oscilloscope, averaging on, The difference between the rising edge rate (average) of DIF versus the falling edge rate (average) of DIF#. Measured in a ± 75 mV window around the crosspoint of DIF and DIF#.
32. Rise/Fall matching is derived using the following, $2 * (\text{Trise} - \text{Tfall}) / (\text{Trise} + \text{Tfall})$.
33. This is the time from the valid CLK_IN input clocks and the assertion of the PWRGD signal level at 1.8 V – 2.0 V to the time that stable clocks are output from the buffer chip (PLL locked).
34. All Long Term Accuracy specifications are guaranteed with the assumption that the input clock complies with CK410B+/CK420BQ accuracy requirements. The NB3W800L itself does not contribute to ppm error.

NB3W800L

Table 13. ELECTRICAL CHARACTERISTICS – Current Consumption

($V_{DD} = V_{DDA} = 3.3\text{ V} \pm 5\%$, $T_A = 0^\circ\text{C} - 70^\circ\text{C}$), See Test Loads for Loading Conditions. (Note 36)

Symbol	Parameter	Conditions	Min	Typ	Max	Units
I_{DDVDD}	Operating Current (Note 35)	133 MHz, VDD rail		94	105	mA
		133 MHz, VDDA + VDDR rail, PLL Mode		38	50	mA
$I_{DDVDDPD}$	Powerdown Current (Note 35)	Power Down, VDD Rail		2.0	3.5	mA
		Power Down, VDDA Rail		0.5	1.0	mA

35. Guaranteed by design and characterization, not tested in production.

36. $C_L = 2\text{ pF}$ with $R_S = 27\ \Omega$ for $Z_o = 85\ \Omega$ differential trace impedance.

Table 14. ELECTRICAL CHARACTERISTICS – Skew and Differential Jitter Parameters

($V_{DD} = V_{DDA} = 3.3\text{ V} \pm 5\%$, $T_A = 0^\circ\text{C} - 70^\circ\text{C}$), See Test Loads for Loading Conditions.

Symbol	Parameter	Conditions	Min	Typ	Max	Units
t_{SPO_PLL}	CLK_IN, DIF[x:0] (Notes 37, 38, 40, 41, 44)	Input-to-Output Skew in PLL mode nominal value @ 25°C, 3.3 V	-100		100	ps
t_{PD_BYP}	CLK_IN, DIF[x:0] (Notes 37, 38, 40, 41, 44)	Input-to-Output Skew in Bypass mode nominal value @ 25°C, 3.3 V	2.5		4.5	ns
t_{DSPO_PLL}	CLK_IN, DIF[x:0] (Notes 37, 38, 40, 41, 44)	Input-to-Output Skew Variation in PLL mode across voltage and temperature	-100		100	ps
t_{DSPO_BYP}	CLK_IN, DIF[x:0] (Notes 37, 38, 40, 41, 44)	Input-to-Output Skew Variation in Bypass mode across voltage and temperature	-250		250	ps
t_{SKEW_ALL}	DIF{x:0] (Notes 37, 38, 40, 44)	Output-to-Output Skew across all outputs (Common to Bypass and PLL mode)			50	ps
$j_{peak-hbw}$	PLL Jitter Peaking (Notes 37, 43, 44)	HBW_BYP_LBW# = 1			2.5	dB
$j_{peak-lbw}$	PLL Jitter Peaking (Notes 37, 43, 44)	HBW_BYP_LBW# = 0			2	dB
pll_{HBW}	PLL Bandwidth (Notes 37, 44, 45)	HBW_BYP_LBW# = 1	2	3	4	MHz
pll_{LBW}	PLL Bandwidth (Notes 37, 44, 45)	HBW_BYP_LBW# = 0	0.7	1	1.4	MHz
t_{DC}	Duty Cycle (Note 37, 47)	Measured differentially, PLL and Bypass Mode	45	50	55	%
t_{DCD}	Duty Cycle Distortion (Notes 37, 46)	Measured differentially, Bypass Mode @ 100 MHz	-2	0	2	%
$t_{jyc-cyc}$	Jitter, Cycle to cycle (Notes 37, 47)	PLL mode			50	ps
		Additive Jitter in Bypass Mode			50	ps

37. $C_L = 2\text{ pF}$ with $R_S = 27\ \Omega$ for $Z_o = 85\ \Omega$ differential trace impedance. Input to output skew is measured at the first output edge following the corresponding input.

38. Measured from differential cross-point to differential cross-point. This parameter can be tuned with external feedback path, if present.

39. All Bypass Mode Input-to-Output specs refer to the timing between an input edge and the specific output edge created by it.

40. This parameter is deterministic for a given device

41. Measured with scope averaging on to find mean value.

42. t is the period of the input clock

43. Measured as maximum pass band gain. At frequencies within the loop BW, highest point of magnification is called PLL jitter peaking.

44. Guaranteed by design and characterization, not tested in production.

45. Measured at 3 db down or half power point.

46. Duty cycle distortion is the difference in duty cycle between the output and the input clock when the device is operated in bypass mode.

47. Measured from differential waveform. Bypass mode, input duty cycle = 50%.

NB3W800L

Table 15. ELECTRICAL CHARACTERISTICS – PHASE JITTER PARAMETERS

(V_{DD} = V_{DDA} = 3.3 V ±5%, TA = 0°C – 70°C), See Test Loads for Loading Conditions. (Note 36)

Symbol	Parameter	Conditions	Min	Typ	Max	Units
t _{jphPCleG1}	Phase Jitter, PLL Mode (Note 48)	PCle Gen 1 (Notes 49, 50)		13	86	ps (p-p)
t _{jphPCleG2}		PCle Gen 2 Lo Band 10 kHz < f < 1.5 MHz (Note 49)		0.25	3.0	ps (rms)
		PCle Gen 2 High Band 1.5 MHz < f < Nyquist (50 MHz) (Note 49)		1.05	3.1	ps (rms)
t _{jphPCleG3}		PCle Gen 3 (PLL BW of 2–4 MHz, CDR = 10 MHz) (Notes 49, 51)		0.21	1.0	ps (rms)
t _{jphPCleG4}		PCle Gen 4 (PLL BW of 2–4 MHz, CDR = 10 MHz) (Notes 49, 51)		0.21	0.5	ps (rms)
t _{jphUPI}		UPI (9.6 Gb/s, 10.4 Gb/s or 11.2 Gb/s, 100 MHz, 12 UI)		0.7	1.0	ps (rms)
t _{jphQPI_SMI}		QPI & SMI (100 MHz or 133 MHz, 4.8 Gb/s, 6.4 Gb/s 12 UI) (Note 52)		0.14	0.5	ps (rms)
		QPI & SMI (100 MHz, 8.0 Gb/s, 12 UI) (Note 52)		0.1	0.3	ps (rms)
		QPI & SMI (100 MHz, 9.6 Gb/s, 12 UI) (Note 52)		0.08	0.2	ps (rms)
t _{jphPCleG1}		Additive Phase Jitter, Bypass mode (Note 48)	PCle Gen 1 (Notes 49, 50)			10
t _{jphPCleG2}	PCle Gen 2 Lo Band 10 kHz < f < 1.5 MHz (Notes 49, 53)				0.3	ps (rms)
	PCle Gen 2 High Band 1.5 MHz < f < Nyquist (50 MHz) (Notes 49, 53)				0.6	ps (rms)
t _{jphPCleG3}	PCle Gen 3 (PLL BW of 2–4 MHz, 2–5 MHz, CDR = 10 MHz) (Notes 49, 51, 53)				0.2	ps (rms)
t _{jphQPI_SMI}	QPI & SMI (100 MHz or 133 MHz, 4.8 Gb/s, 6.4 Gb/s 12 UI) (Notes 52, 53)				0.2	ps (rms)
	QPI & SMI (100 MHz, 8.0 Gb/s, 12 UI) (Notes 52, 53)				0.1	ps (rms)
	QPI & SMI (100 MHz, 9.6 Gb/s, 12 UI) (Notes 52, 53)				0.1	ps (rms)

48. Applies to all outputs.

49. See <http://www.pcisig.com> for complete specs

50. Sample size of at least 100K cycles. This figures extrapolates to 108ps pk-pk @ 1M cycles for a BER of 1–12.

51. Subject to final ratification by PCI SIG.

52. Calculated from Intel-supplied Clock Jitter Tool v 1.6.3

53. For RMS figures, additive jitter is calculated by solving the following equation: (Additive jitter)² = (total jitter)² - (input jitter)²

NB3W800L

Table 16. CLOCK PERIODS – Differential Outputs with Spread Spectrum Disabled

SSC OFF	Center Freq. MHz	Measurement Window							Units
		1 Clock	1 μ s	0.1 s	0.1 s	0.1 s	1 μ s	1 Clock	
		-c2c Jitter Abs Per Min	-SSC Short-Term Average Min	- ppm Long-Term Average Min	0 ppm Period Nominal	+ ppm Long-Term Average Max	+SSC Short-Term Average Max	+c2c Jitter Abs Per Max	
DIF (Notes 54, 55, 56)	100.00	9.94900		9.99900	10.00000	10.00100		10.05100	ns
DIF (Notes 54, 55, 57)	133.33	7.44925		7.49925	7.50000	7.50075		7.55075	ns

Table 17. CLOCK PERIODS – Differential Outputs with Spread Spectrum Enabled

SSC ON	Center Freq. MHz	Measurement Window							Units
		1 Clock	1 μ s	0.1 s	0.1 s	0.1 s	1 μ s	1 Clock	
		-c2c Jitter Abs Per Min	-SSC Short-Term Average Min	- ppm Long-Term Average Min	0 ppm Period Nominal	+ ppm Long-Term Average Max	+SSC Short-Term Average Max	+c2c Jitter Abs Per Max	
DIF (Notes 54, 55, 56)	99.75	9.94906	9.99906	10.02406	10.02506	10.02607	10.05107	10.10107	ns
DIF (Notes 54, 55, 57)	133.00	7.44930	7.49930	7.51805	7.51880	7.51955	7.53830	7.58830	ns

54. Guaranteed by design and characterization, not tested in production.

55. All Long Term Accuracy specifications are guaranteed with the assumption that the input clock complies with CK420BQ/CK410B+ accuracy requirements (± 100 ppm). The device itself does not contribute to ppm error.

56. Driven by SRC output of main clock, 100 MHz PLL Mode or Bypass mode

57. Driven by CPU output of main clock, 133 MHz PLL Mode or Bypass mode

MEASUREMENT POINTS FOR DIFFERENTIAL

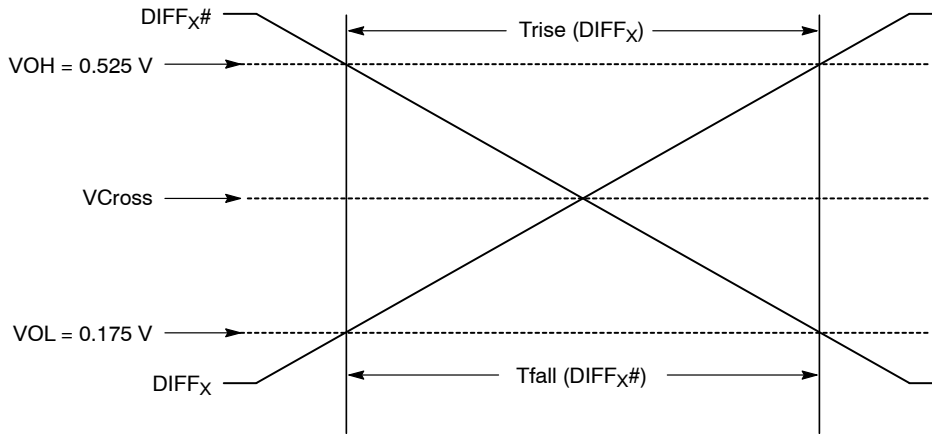

Figure 3. Single-Ended Measurement Points for Trise, Tfall

MEASUREMENT POINTS FOR DIFFERENTIAL

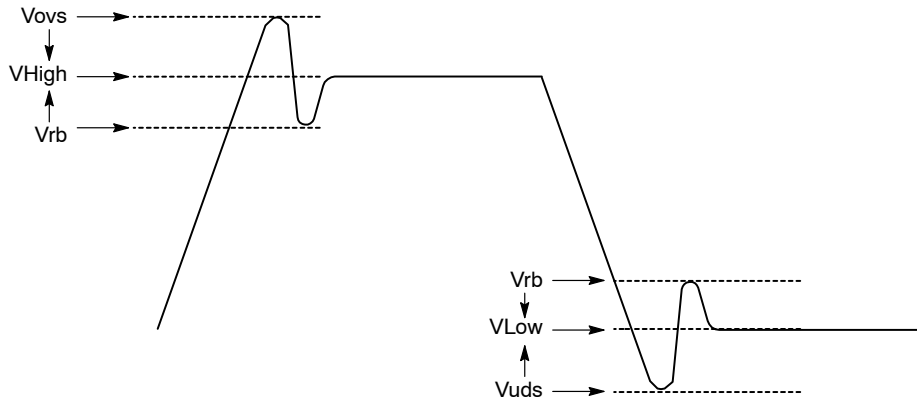

Figure 4. Single-Ended Measurement Points for Vovs, Vuds, Vrb

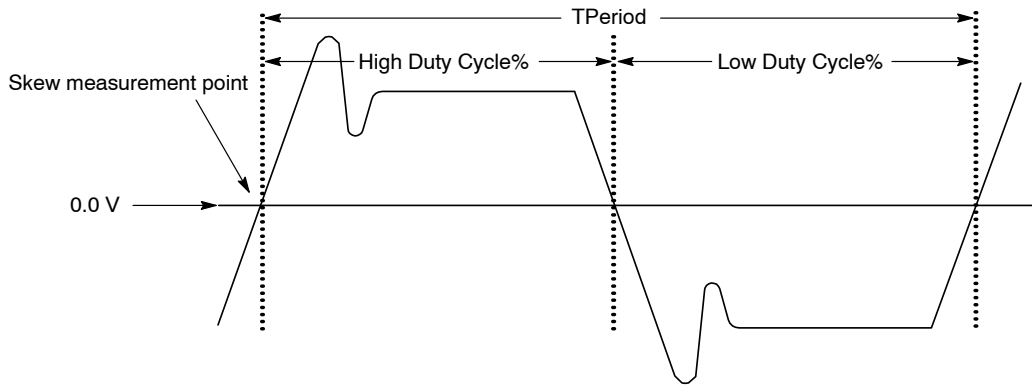

Figure 5. Differential (DIFF_x – DIFF_x #) Measurement Points (Tperiod, Duty Cycle, Jitter)

Test Loads

Differential Output Terminations	
DIF Zo (Ω)	Rs (Ω)
100	33
85	27

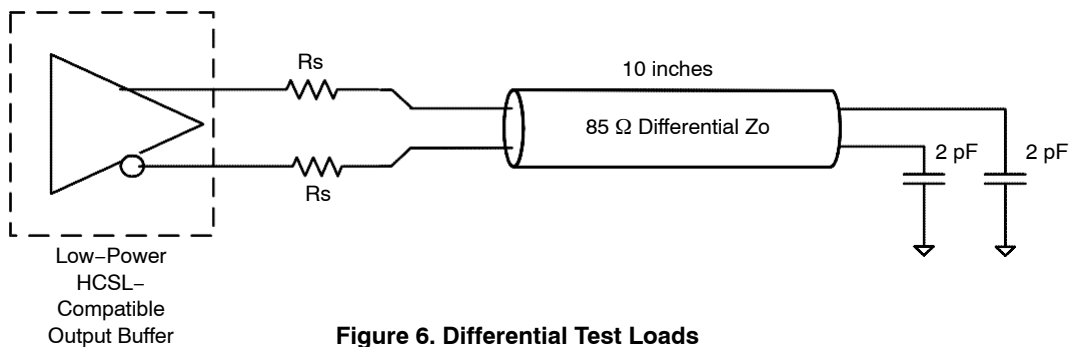

Figure 6. Differential Test Loads

SIGNAL AND FEATURE OPERATION

CLK_IN, CLK_IN#

The differential input clock is expected to be sourced from a clock synthesizer with an HCSL-compatible output, e.g. CK420BQ, CK-NET, CK-uS, or CK509B or another driver.

OE# and Output Enables (Control Registers)

Each output can be individually enabled or disabled by SMBus control register bits. Additionally, each output of the DIF[7:0] has a dedicated OE# pin. The OE# pins are asynchronous asserted-low signals. The Output Enable bits in the SMBus registers are active high and are set to enable by default.

The disabled state for the NB3W800L low power NMOS Push-Pull outputs is Low/Low.

Please note that the logic level for assertion or deassertion is different in software than it is on hardware. Output is enabled if OE# pin is pulled low and still maintains software programming logic with output enabled if OE register is true.

The assertion and de-assertion of this signal is absolutely asynchronous.

OE# Assertion (Transition from '1' to '0')

All differential outputs that were tristated will resume normal operation in a glitch free manner.

OE# De-Assertion (Transition from '0' to '1')

Corresponding output will transition from normal operation to tri-state in a glitch free manner.

100M_133M# – Frequency Selection

The 100M_133M# is a hardware pin, which programs the appropriate output frequency of the DIF pairs. Note that the CLK_IN frequency is equal to CLK_OUT frequency. An external pull-up or pull-down resistor is attached to this pin to select the input/output frequency.

PWRGD/PWRDN#

PWRGD/PWRDN# is a dual function pin. PWRGD is asserted high and de-asserted low. De-assertion of PWRGD (pulling the signal low) is equivalent to indicating a powerdown condition. PWRGD (assertion) is used by the NB3W800L to sample initial configurations such as frequency select condition and SA selections.

After PWRGD has been asserted high for the first time, the pin becomes a PWRDN# (Power Down) pin that can be used to shut off all clocks cleanly and instruct the device to invoke power savings mode. PWRDN# is a completely asynchronous active low input. When entering power savings mode, PWRDN# should be asserted low **prior to shutting off the input clock or power** to ensure all clocks shut down in a glitch free manner. When PWRDN# is asserted low by two consecutive rising edges of DIF#, all differential outputs are held tri-stated on the next DIF# high to low transition. The assertion and de-assertion of PWRDN# is absolutely asynchronous.

WARNING: Disabling of the CLK_IN input clock prior to assertion of PWRDN# is an undefined mode and not recommended. Operation in this mode may result in glitches, excessive frequency shifting, etc.

Table 18. PWRGD/PWRDN# FUNCTIONALITY

PWRGD/PWRDN#	DIF	DIF#
0	Tri-state	Tri-state
1	Running	Running

HBW_BYPASS_LBW#

The HBW_BYPASS_LBW# is a tri level function input pin. It is used to select between PLL high bandwidth, bypass mode and PLL low bandwidth mode.

POWER FILTERING EXAMPLE

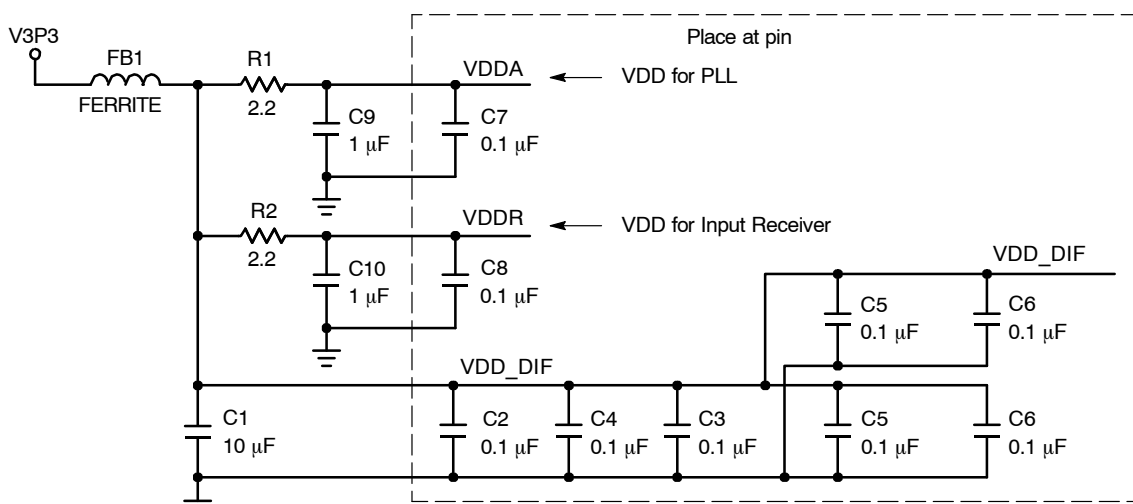

Figure 7. Schematic Example of the NB3W800L Power Filtering

Buffer Power-Up State Machine

Table 19. BUFFER POWER-UP STATE MACHINE

State	Description
0	3.3 V Buffer power off
1	After 3.3 V supply is detected to rise above 3.135 V, the buffer enters State 1 and initiates a 0.1 ms–0.3 ms delay.
2	Buffer waits for a valid clock on the CLK input and PWRDN# de-assertion (or PWRGD assertion low to high)
3	Once the PLL is locked to the CLK_IN input clock, the buffer enters state 3 and enables outputs for normal operation. (Notes 58, 59)

58. The total power up latency from power on to all outputs active must be less than 1.8 ms (assuming a valid clock is present on CLK_IN input).
 59. If power is valid and powerdown is de-asserted (PWRGD asserted) but no input clocks are present on the CLK_IN input, DIF clocks must remain disabled. Only after valid input clocks are detected, valid power, PWRDN# de-asserted (PWRGD asserted) with the PLL locked/stable and the DIF outputs enabled.

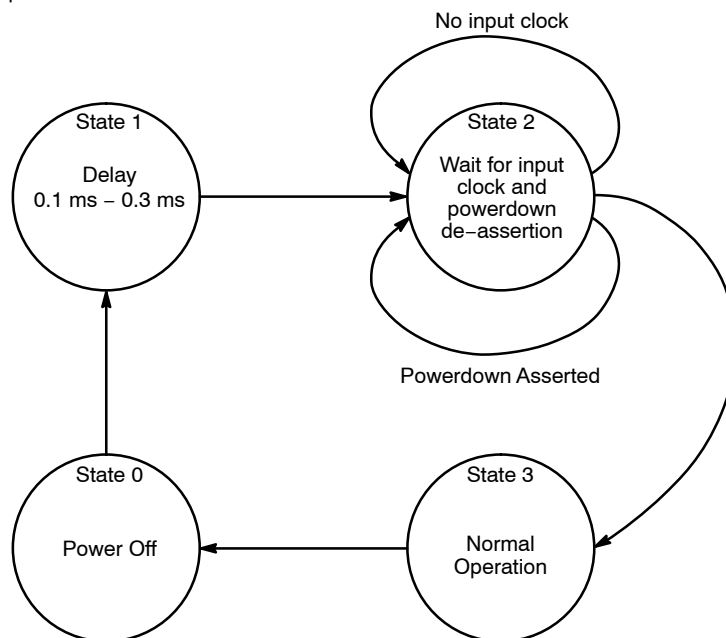

Figure 8. Buffer Power-Up State Diagram

Device Power-Up Sequence

Follow the power-up sequence below for proper device functionality:

1. PWRGD/PWRDN# pin must be Low.
2. Assign remaining control pins to their required state (100M_133M#, HBW_BYPASS_LBW#, SDA, SCL)

3. Apply power to the device.
4. Once the VDD pin has reached a valid VDDmin level (3.3V -5%), the PWRGD/PWRDN# pin must be asserted High. See Figure 9.

Note: If no clock is present on the CLK_IN/CLK_IN# pins when device is powered up, there will be no clock on DIF/DIF# outputs.

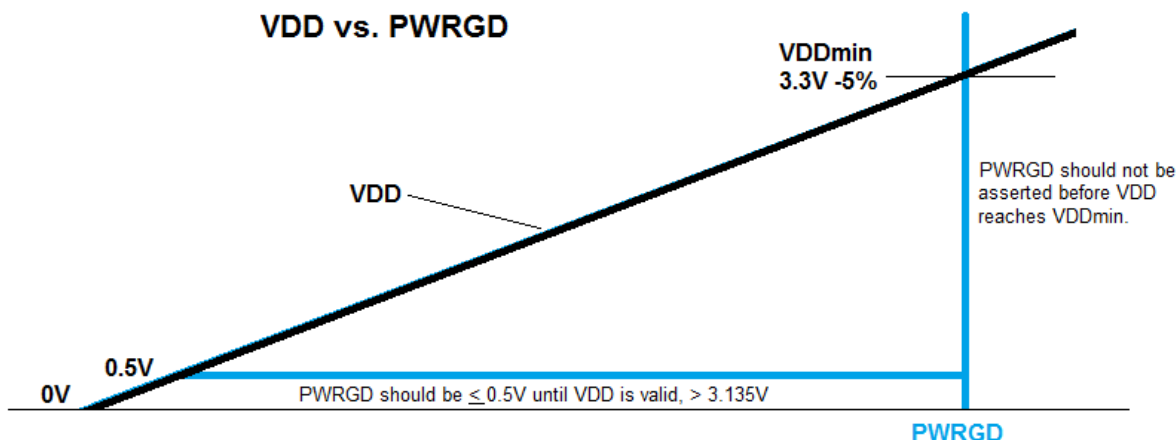

Figure 9. PWRGD and VDD Relationship Diagram

GENERAL SMBUS SERIAL INTERFACE INFORMATION FOR NB3W800L

How to Write

- Controller (host) sends a start bit
- Controller (host) sends the write address
- Clock(device) will **acknowledge**
- Controller (host) sends the beginning byte location = N
- Clock(device) will **acknowledge**
- Controller (host) sends the byte count = X
- Clock(device) will **acknowledge**
- Controller (host) starts sending Byte N through Byte N+X-1
- Clock(device) will **acknowledge** each byte **one at a time**
- Controller (host) sends a Stop bit

How to Read

- Controller (host) will send a start bit
- Controller (host) sends the write address
- Clock(device) will **acknowledge**
- Controller (host) sends the beginning byte location = N
- Clock(device) will **acknowledge**
- Controller (host) will send a separate start bit
- Controller (host) sends the read address
- Clock(device) will **acknowledge**
- Clock(device) will send the data byte count = X
- Clock(device) sends Byte N+X-1
- Clock(device) sends **Byte 0 through Byte X (if X(H) was written to Byte 8)**
- Controller (host) will need to acknowledge each byte
- Controller (host) will send a not acknowledge bit
- Controller (host) will send a stop bit

Index Block Write Operation			
Controller (Host)		X Byte	Clock (Device)
T	starT bit		
Slave Address			
WR	WRite		
			ACK
Beginning Byte = N			
			ACK
Data Byte Count = X			
			ACK
Beginning Byte N			
			ACK
O			O
O			O
O			O
			O
Byte N + X - 1			
			ACK
P	stoP bit		

Index Block Read Operation			
Controller (Host)		X Byte	Clock (Device)
T	starT bit		
Slave Address			
WR	WRite		
			ACK
Beginning Byte = N			
			ACK
RT	Repeat starT		
Slave Address			
RD	ReaD		
			ACK
			Data Byte Count = X
ACK			
			Beginning Byte N
ACK			
			O
			O
			O
			O
			Byte N + X - 1
N	Not acknowledge		
P	stoP bit		

NB3W800L

Table 20. SMBus TABLE: PLL MODE, AND FREQUENCY SELECT REGISTER

Byte 0	Pin #	Name	Control Function	Type	0	1	Default
Bit 7	48	PLL Mode 1	PLL Operating Mode Rd back 1	R	See PLL Operating Mode Readback Table		Latched at power up
Bit 6	48	PLL Mode 0	PLL Operating Mode Rd back 0	R			Latched at power up
Bit 5		Reserved					0
Bit 4		Reserved					0
Bit 3		PLL_SW_EN	Enable S/W control of PLL BW	RW	HW Latch	SMBus Control	0
Bit 2		PLL Mode 1	PLL Operating Mode 1	RW	See PLL Operating Mode Readback Table		1
Bit 1		PLL Mode 0	PLL Operating Mode 0	RW			1
Bit 0	47	100M_133M#	Frequency Select Readback	R	133 MHz	100 MHz	Latched at power up

NOTE: Setting bit 3 to '1' allows the user to override the Latch value from pin 48 via use of bits 2 and 1. Use the values from the PLL Operating Mode Readback Table. Note that Bits 7 and 6 will keep the value originally latched on pin 48. A warm reset of the system will have to be accomplished if the user changes these bits.

Table 21. SMBus TABLE: OUTPUT CONTROL REGISTER

Byte 1	Pin #	Name	Control Function	Type	0	1	Default
Bit 7	32/33	DIF_5_En	Output Control - '0' overrides OE# pin	RW	Low/Low	Enable	1
Bit 6	28/29	DIF_4_En	Output Control - '0' overrides OE# pin	RW			1
Bit 5	25/26	DIF_3_En	Output Control - '0' overrides OE# pin	RW			1
Bit 4	21/22	DIF_2_En	Output Control - '0' overrides OE# pin	RW			1
Bit 3		Reserved					1
Bit 2	16/17	DIF_1_En	Output Control - '0' overrides OE# pin	RW	Low/Low	Enable	1
Bit 1	13/14	DIF_0_En	Output Control - '0' overrides OE# pin	RW			1
Bit 0		Reserved					1

Table 22. SMBus TABLE: OUTPUT CONTROL REGISTER

Byte 2	Pin #	Name	Control Function	Type	0	1	Default
Bit 7		Reserved					0
Bit 6		Reserved					0
Bit 5		Reserved					0
Bit 4		Reserved					0
Bit 3		Reserved					1
Bit 2	39/40	DIF_7_En	Output Control - '0' overrides OE# pin	RW	Low/Low	Enable	1
Bit 1		Reserved					1
Bit 0	35/36	DIF_6_En	Output Control - '0' overrides OE# pin	RW	Low/Low	Enable	1

Table 23. SMBus TABLE: RESERVED REGISTER

Byte 3	Pin #	Name	Control Function	Type	0	1	Default
Bit 7		Reserved					0
Bit 6		Reserved					0
Bit 5		Reserved					0
Bit 4		Reserved					0
Bit 3		Reserved					0
Bit 2		Reserved					0
Bit 1		Reserved					0
Bit 0		Reserved					0

NB3W800L

Table 24. SMBus TABLE: RESERVED REGISTER

Byte 4	Pin #	Name	Control Function	Type	0	1	Default
Bit 7			Reserved				0
Bit 6			Reserved				0
Bit 5			Reserved				0
Bit 4			Reserved				0
Bit 3			Reserved				0
Bit 2			Reserved				0
Bit 1			Reserved				0
Bit 0			Reserved				0

Table 25. SMBus TABLE: VENDOR & REVISION ID REGISTER

Byte 5	Pin #	Name	Control Function	Type	0	1	Default
Bit 7	-	RID3	REVISION ID	R	A rev = 0000		0
Bit 6	-	RID2		R			0
Bit 5	-	RID1		R			0
Bit 4	-	RID0		R			0
Bit 3	-	VID3	VENDOR ID	R	-	-	1
Bit 2	-	VID2		R	-	-	1
Bit 1	-	VID1		R	-	-	1
Bit 0	-	VID0		R	-	-	1

Table 26. SMBus TABLE: DEVICE ID

Byte 6	Pin #	Name	Control Function	Type	0	1	Default
Bit 7	-		Device ID 7 (MSB)	R			1
Bit 6	-		Device ID 6	R			1
Bit 5	-		Device ID 5	R			1
Bit 4	-		Device ID 4	R			0
Bit 3	-		Device ID 3	R			0
Bit 2	-		Device ID 2	R			1
Bit 1	-		Device ID 1	R			1
Bit 0	-		Device ID 0	R			1

Table 27. SMBus TABLE: BYTE COUNT REGISTER

Byte 7	Pin #	Name	Control Function	Type	0	1	Default
Bit 7			Reserved				0
Bit 6			Reserved				0
Bit 5			Reserved				0
Bit 4	-	BC4	Writing to this register configures how many bytes will be read back.	RW	Default value is 8 hex, so 9 bytes (0 to 8) will be read back by default.		0
Bit 3	-	BC3		RW			1
Bit 2	-	BC2		RW			0
Bit 1	-	BC1		RW			0
Bit 0	-	BC0		RW			0

NB3W800L

PCIe is a registered trademark of PCI-Special Interest Group (PCI-SIG) Corporation. Intel is a registered trademark of Intel Corporation in the U.S. and/or other countries.



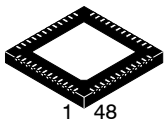

1 48
SCALE 2:1

QFN48 6x6, 0.4P
CASE 485DP
ISSUE O

DATE 27 MAY 2014

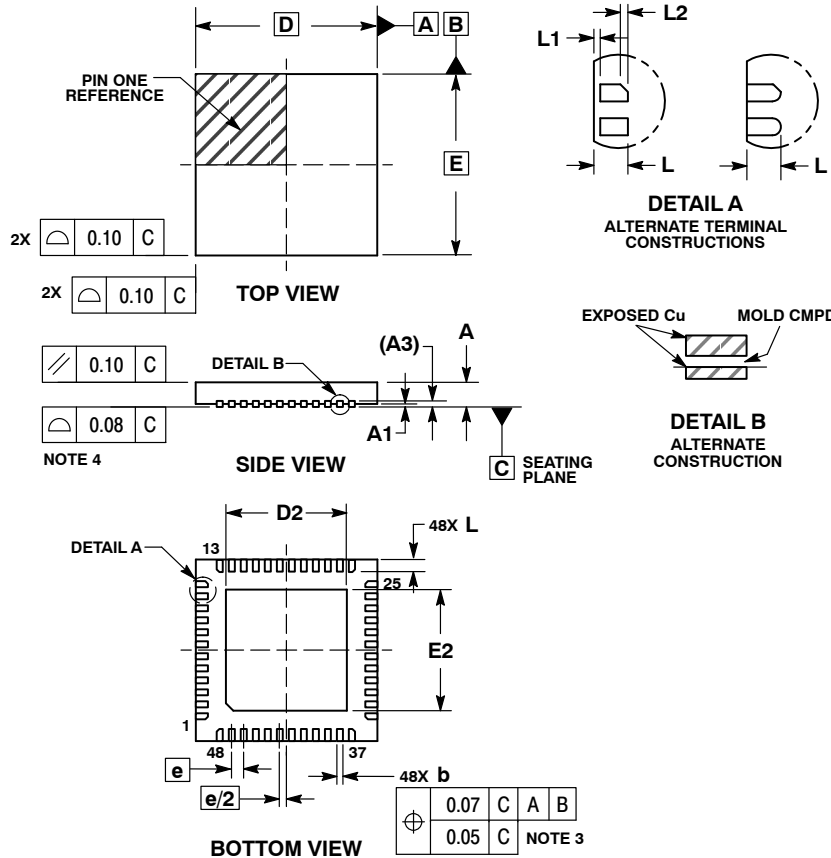

- NOTES:
1. DIMENSIONING AND TOLERANCING PER ASME Y14.5M, 1994.
 2. CONTROLLING DIMENSIONS: MILLIMETERS.
 3. DIMENSION b APPLIES TO PLATED TERMINAL AND IS MEASURED BETWEEN 0.15 AND 0.30mm FROM TERMINAL TIP
 4. COPLANARITY APPLIES TO THE EXPOSED PAD AS WELL AS THE TERMINALS.

MILLIMETERS		
DIM	MIN	MAX
A	0.80	1.00
A1	0.00	0.05
A3	0.20	REF
b	0.15	0.25
D	6.00	BSC
D2	3.90	4.10
E	6.00	BSC
E2	3.90	4.10
e	0.40	BSC
L	0.30	0.50
L1	0.00	0.15
L2	0.08	REF

GENERIC MARKING DIAGRAM*

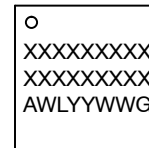

- XXX = Specific Device Code
- A = Assembly Location
- WL = Wafer Lot
- YY = Year
- WW = Work Week
- G = Pb-Free Package

*This information is generic. Please refer to device data sheet for actual part marking. Pb-Free indicator, "G" or microdot "▪", may or may not be present.

SOLDERING FOOTPRINT*

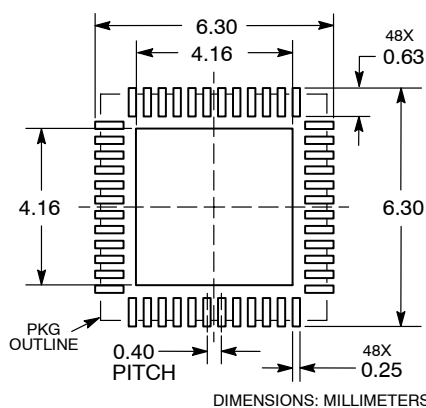

*For additional information on our Pb-Free strategy and soldering details, please download the ON Semiconductor Soldering and Mounting Techniques Reference Manual, SOLDERRM/D.

DOCUMENT NUMBER:	98AON85907F	Electronic versions are uncontrolled except when accessed directly from the Document Repository. Printed versions are uncontrolled except when stamped "CONTROLLED COPY" in red.
DESCRIPTION:	QFN48 6x6, 0.4P	PAGE 1 OF 1

onsemi and Onsemi are trademarks of Semiconductor Components Industries, LLC dba onsemi or its subsidiaries in the United States and/or other countries. onsemi reserves the right to make changes without further notice to any products herein. onsemi makes no warranty, representation or guarantee regarding the suitability of its products for any particular purpose, nor does onsemi assume any liability arising out of the application or use of any product or circuit, and specifically disclaims any and all liability, including without limitation special, consequential or incidental damages. onsemi does not convey any license under its patent rights nor the rights of others.

onsemi, **Onsemi**, and other names, marks, and brands are registered and/or common law trademarks of Semiconductor Components Industries, LLC dba "**onsemi**" or its affiliates and/or subsidiaries in the United States and/or other countries. **onsemi** owns the rights to a number of patents, trademarks, copyrights, trade secrets, and other intellectual property. A listing of **onsemi**'s product/patent coverage may be accessed at www.onsemi.com/site/pdf/Patent-Marking.pdf. **onsemi** reserves the right to make changes at any time to any products or information herein, without notice. The information herein is provided "as-is" and **onsemi** makes no warranty, representation or guarantee regarding the accuracy of the information, product features, availability, functionality, or suitability of its products for any particular purpose, nor does **onsemi** assume any liability arising out of the application or use of any product or circuit, and specifically disclaims any and all liability, including without limitation special, consequential or incidental damages. Buyer is responsible for its products and applications using **onsemi** products, including compliance with all laws, regulations and safety requirements or standards, regardless of any support or applications information provided by **onsemi**. "Typical" parameters which may be provided in **onsemi** data sheets and/or specifications can and do vary in different applications and actual performance may vary over time. All operating parameters, including "Typicals" must be validated for each customer application by customer's technical experts. **onsemi** does not convey any license under any of its intellectual property rights nor the rights of others. **onsemi** products are not designed, intended, or authorized for use as a critical component in life support systems or any FDA Class 3 medical devices or medical devices with a same or similar classification in a foreign jurisdiction or any devices intended for implantation in the human body. Should Buyer purchase or use **onsemi** products for any such unintended or unauthorized application, Buyer shall indemnify and hold **onsemi** and its officers, employees, subsidiaries, affiliates, and distributors harmless against all claims, costs, damages, and expenses, and reasonable attorney fees arising out of, directly or indirectly, any claim of personal injury or death associated with such unintended or unauthorized use, even if such claim alleges that **onsemi** was negligent regarding the design or manufacture of the part. **onsemi** is an Equal Opportunity/Affirmative Action Employer. This literature is subject to all applicable copyright laws and is not for resale in any manner.

ADDITIONAL INFORMATION

TECHNICAL PUBLICATIONS:

Technical Library: www.onsemi.com/design/resources/technical-documentation
onsemi Website: www.onsemi.com

ONLINE SUPPORT: www.onsemi.com/support

For additional information, please contact your local Sales Representative at www.onsemi.com/support/sales