

# Microphone Pre-Amplifier with Digital Output

## FAN3852

### Description

The FAN3852 integrates a pre-amplifier, LDO, and ADC that converts Electret Condenser Microphone (ECM) outputs to digital Pulse Density Modulation (PDM) data streams. The pre-amplifier accepts analog signals from the ECM and drives an over-sampled sigma delta Analog-to-Digital Converter (ADC) and outputs PDM data. The PDM digital audio has the advantage of noise rejection and easy interface to mobile handset processors.

The FAN3852 features an integrated LDO and is powered from the system supply rails up to 3.63 V, with low power consumption of only 0.85 mW and less than 20  $\mu$ W in Power-Down Mode.

### Features

- Optimized for Mobile Handset and Notebook PC Microphone Applications
- Accepts Input from Electret Condenser Microphones (ECM)
- Pulse Density Modulation (PDM) Output
- Standard 5-Wire Digital Interface
- Low Input Capacitance, High PSR, 20 kHz Pre-Amplifier
- Low-Power 1.5  $\mu$ A Sleep Mode
- Typical 420  $\mu$ A Supply Current
- SNR of 62 dB (A) for 16 dB Gain
- Total Harmonic Distortion 0.02%
- Input Clock Frequency Range of 1–4 MHz
- Integrated Low Drop-Out Regulator (LDO)
- Small 1.242 mm  $\times$  0.842 mm 6-Ball, 0.400 mm pitch standard WLCSP Package
- 1.5 kV HBM ESD on MIC Input

### Typical Applications

- Electret Condenser Microphones with Digital Output
- Mobile Handset
- Headset Accessories
- Personal Computer (PC)

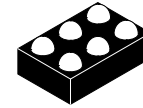

WLCSP-6  
CASE 567TS

### PIN CONFIGURATION

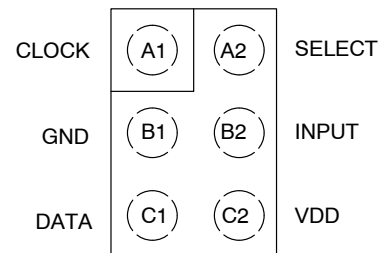

Top View

### MARKING DIAGRAM

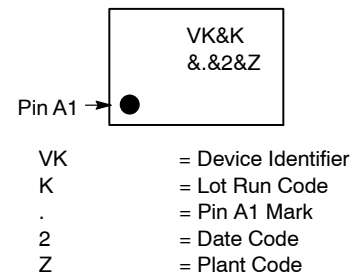

### ORDERING INFORMATION

See detailed ordering and shipping information on page 2 of this data sheet.

# FAN3852

## ORDERING INFORMATION

Part Number	Operating Temperature Range	Package	Packing Method†
FAN3852UC16X	-40°C to 85°C	6 Ball, Wafer-Level Chip-Scale Package (WLCSF)	3000 Units/Tape & Reel

†For information on tape and reel specifications, including part orientation and tape sizes, please refer to our Tape and Reel Packaging Specifications Brochure, BRD8011/D.

## INTERNAL BLOCK DIAGRAM

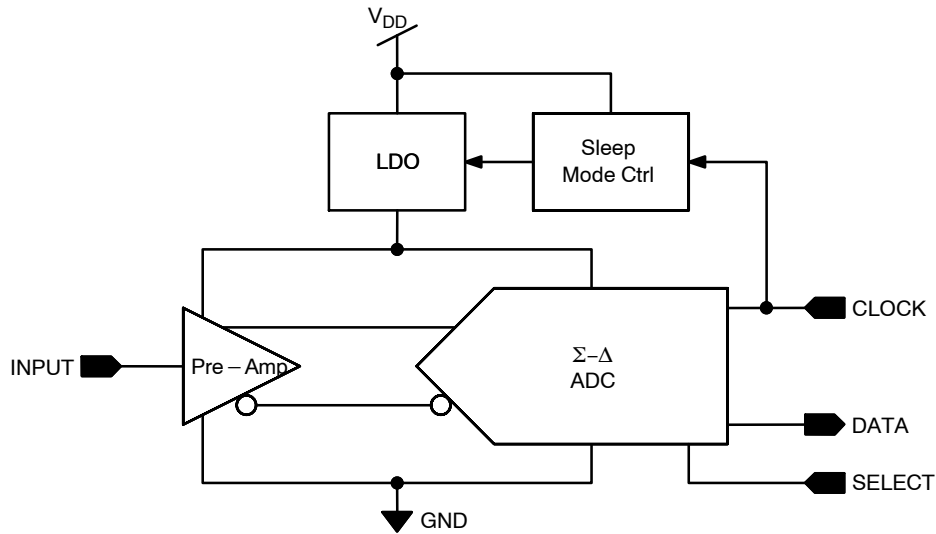

Figure 1. Block Diagram

Table 1. PIN DEFINITIONS

Pin #	Name	Type	Description
A1	CLOCK	Input	Clock Input
B1	GND	Input	Ground Pin
C1	DATA	Output	PDM Output – 1 Bit ADC
A2	SELECT	Input	Rising or Falling Clock Edge Select
B2	INPUT	Input	Microphone Input
C2	VDD	Input	Device Power Pin

Table 2. ABSOLUTE MAXIMUM RATINGS

Symbol	Parameter	Min.	Max.	Unit
$V_{DD}$	DC Supply Voltage	-0.3	4.0	V
$V_{IO}$	Digital I/O	-0.3	$V_{DD} + 0.3$	V
	Microphone Input	-0.3	2.2	
ESD	Human Body Model, JESD22-A114, All Pins Except Microphone Input	±8		kV
	Human Body Model, JESD2-A114 – Microphone Input	±1.5		

Stresses exceeding those listed in the Maximum Ratings table may damage the device. If any of these limits are exceeded, device functionality should not be assumed, damage may occur and reliability may be affected.

1. This device is fabricated using CMOS technology and is therefore susceptible to damage from electrostatic discharges. Appropriate precautions must be taken during handling and storage of this device to prevent exposure to ESD.

# FAN3852

**Table 3. RELIABILITY INFORMATION**

Symbol	Rating	Min.	Typ.	Max.	Unit
T <sub>J</sub>	Junction Temperature			+150	°C
T <sub>STG</sub>	Storage Temperature Range	-65		+125	°C
T <sub>RFLW</sub>	Peak Reflow Temperature			+260	°C
θ <sub>JA</sub>	Thermal Resistance, JEDEC Standard, Multilayer Test Boards, Still Air		90		°C/W

2. T<sub>A</sub> = 25°C unless otherwise specified

**Table 4. RECOMMENDED OPERATING CONDITIONS**

Symbol	Rating	Min.	Typ.	Max.	Unit
T <sub>A</sub>	Operating Temperature Range	-40		+85	°C
V <sub>DD</sub>	Supply Voltage Range	1.64	1.80	3.63	V
T <sub>RF-CLK</sub>	Clock Rise and Fall Time			10	ns

Functional operation above the stresses listed in the Recommended Operating Ranges is not implied. Extended exposure to stresses beyond the Recommended Operating Ranges limits may affect device reliability.

**Table 5. DEVICE SPECIFIC ELECTRICAL CHARACTERISTICS**

Symbol	Value	FAN3852UC16X			Unit
		Min.	Typ.	Max.	
SNR	Signal-to-Noise Ratio f <sub>IN</sub> = 1 kHz (1 Pa), A-Weighted		62		dB (A)
e <sub>N</sub>	Total Input RMS Noise 20 Hz to 20 kHz, A-Weighted		5.74	6.80	μV <sub>RMS</sub>
V <sub>IN</sub>	Maximum Input Signal f <sub>IN</sub> = 1 kHz, THD + N < 10%, Level = 0 V			448	mV <sub>PP</sub>

3. Guaranteed by characterization and/or design. Not production tested.

**Table 6. ELECTRICAL CHARACTERISTICS**

Unless otherwise specified, all limits are guaranteed for T<sub>A</sub> = 25°C, V<sub>DD</sub> = 1.8 V, V<sub>IN</sub> = 94 dB (SPL) and f<sub>CLK</sub> = 2.4 MHz.  
Duty Cycle = 50% and C<sub>MIC</sub> = 15 pF

Symbol	Parameter	Condition	Min.	Typ.	Max.	Unit
V <sub>DD</sub>	Supply Voltage Range		1.64	1.80	3.63	V
I <sub>DD</sub>	Supply Current	INPUT = AC Coupled to GND, CLOCK = On, No Load		420		μA
I <sub>SLEEP</sub>	Sleep Mode Current	f <sub>CLK</sub> = GND		1.50	8.0	μA
PSR	Power Supply Rejection (Note 5)	INPUT = AC Coupled to GND, Test Signal on V <sub>DD</sub> = 217 Hz, Square Wave and Broadband Noise (Note 4), Both 100 mV <sub>P-P</sub>		-74		dBFS
IN <sub>NOM</sub>	Nominal Sensitivity (Note 6)	INPUT = 94 dB SPL (1 Pa)		-26		dBFS
THD	Total Harmonic Distortion (Note 7)	f <sub>IN</sub> = 1 KHz, INPUT = -26 dBFS		0.02	0.20	%
THD+N	THD and Noise (Note 5)	50 Hz ≤ f <sub>IN</sub> ≤ 1 kHz, INPUT = -20 dBFS		0.2	1.0	%
		f <sub>IN</sub> = 1 KHz, INPUT = -5 dBFS		1.0	5.0	
		f <sub>IN</sub> = 1 KHz, INPUT = 0 dBFS		5.0	10.0	
C <sub>IN</sub>	Input Capacitance (Note 8)	INPUT		1.3		pF
R <sub>IN</sub>	Input Resistance (Note 8)	INPUT	>10			GΩ
V <sub>IL</sub>	CLOCK & SELECT Input Logic LOW Level				0.3	V

# FAN3852

**Table 6. ELECTRICAL CHARACTERISTICS** (continued)

Unless otherwise specified, all limits are guaranteed for  $T_A = 25^\circ\text{C}$ ,  $V_{DD} = 1.8\text{ V}$ ,  $V_{IN} = 94\text{ dB (SPL)}$  and  $f_{CLK} = 2.4\text{ MHz}$ .  
Duty Cycle = 50% and  $C_{MIC} = 15\text{ pF}$

Symbol	Parameter	Condition	Min.	Typ.	Max.	Unit
$V_{IH}$	CLOCK & SELECT Input Logic HIGH Level		1.5		$V_{DD}+0.3$	V
$V_{OL}$	Data Output Logic LOW Level				$0.35 \cdot V_{DD}$	V
$V_{OH}$	Data Output Logic HIGH Level		$0.65 \cdot V_{DD}$			V
$V_{OUT}$	Acoustic Overload Point (Note 8)	THD+N < 10%	120			dB SPL
$t_A$	Time from CLOCK Transition to Data becoming Valid	On Falling Edge of CLOCK, SELECT = GND, $C_{LOAD} = 15\text{ pF}$	18	43		ns
$t_B$	Time from CLOCK Transition to Data becoming HIGH-Z	On Rising Edge of CLOCK, SELECT = GND, $C_{LOAD} = 15\text{ pF}$	0	5	16	ns
$t_A$	Time from CLOCK Transition to Data becoming Valid	On Rising Edge of CLOCK, SELECT = $V_{DD}$ , $C_{LOAD} = 15\text{ pF}$	18	58		ns
$t_B$	Time from CLOCK Transition to Data becoming HIGH-Z	On Falling Edge of CLOCK, SELECT = $V_{DD}$ , $C_{LOAD} = 15\text{ pF}$	0	5	16	ns
$f_{CLK}$	Input CLOCK Frequency (Note 9)	Active Mode	1.0	2.4	4.0	MHz
$CLK_{dc}$	CLOCK Duty Cycle (Note 5)		40	50	60	%
$t_{WAKEUP}$	Wake-Up Time (Note 10)	$f_{CLK} = 2.4\text{ MHz}$		0.35	2.00	ms
$t_{FALLASLEAP}$	Fall-Asleep Time (Note 11)	$f_{CLK} = 2.4\text{ MHz}$	0	0.01	1.00	ms
$C_{LOAD}$	Load Capacitance on Data				100	pF

Product parametric performance is indicated in the Electrical Characteristics for the listed test conditions, unless otherwise noted. Product performance may not be indicated by the Electrical Characteristics if operated under different conditions.

4. Pseudo-random noise with triangular probability density function. Bandwidth up to 10 MHz.
5. Guaranteed by characterization. Not production tested.
6. Assuming that 120 dB (SPL) is mapped to 0 dBFS.
7. Assuming an input of -42 dBV (maps to -26 dBFS, 94 dB\_SPL).
8. Guaranteed by design. Not production tested.
9. All parameters are tested at 2.4 MHz. Frequency range guaranteed by characterization.
10. Device wakes up when  $f_{CLK} \geq 300\text{ kHz}$ .
11. Device falls asleep when  $f_{CLK} \leq 70\text{ kHz}$ .

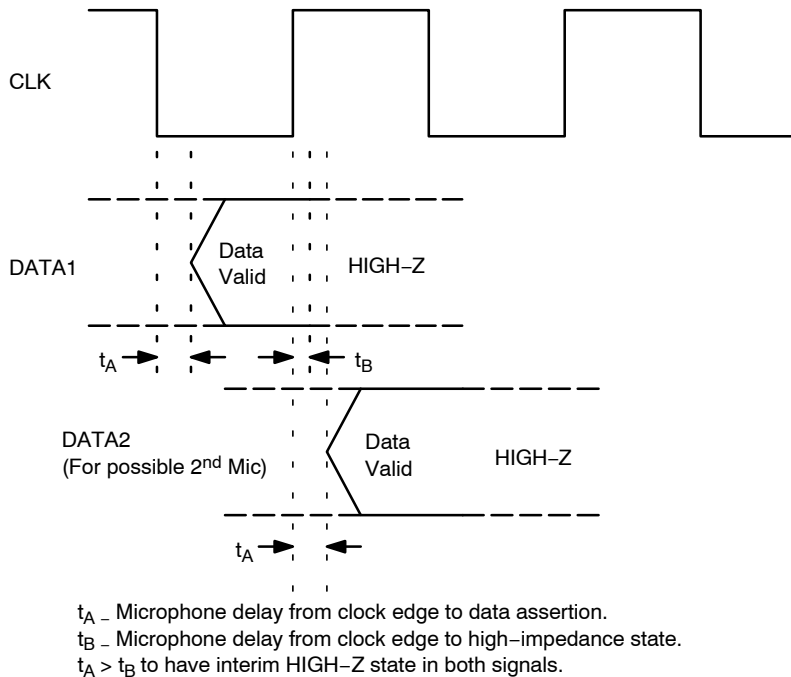

**Figure 2. Interface Timing**

TYPICAL PERFORMANCE CHARACTERISTICS

Unless otherwise specified, all limits are guaranteed for  $T_A = 25^\circ\text{C}$ ,  $V_{DD} = 1.8\text{ V}$ ,  $V_{IN} = 94\text{ dB (SPL)}$ ,  $f_{CLK} = 2.4\text{ MHz}$  and duty Cycle = 50%.

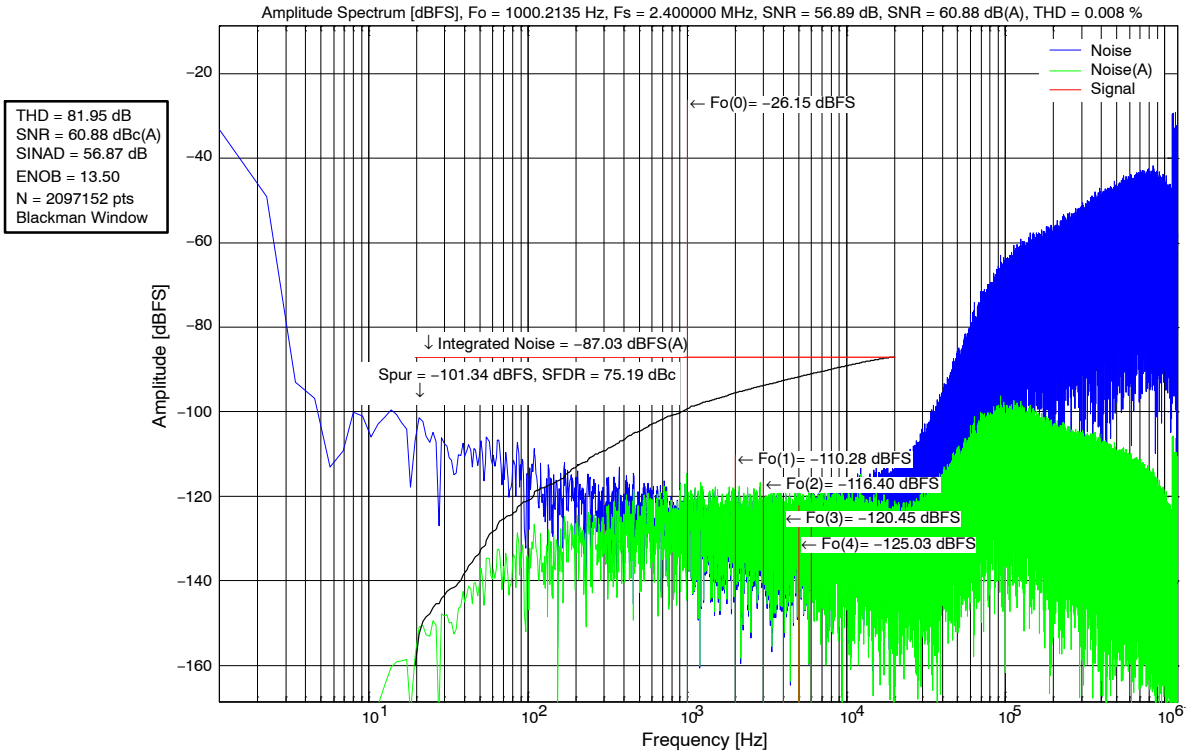

Figure 3. Noise vs. Frequency

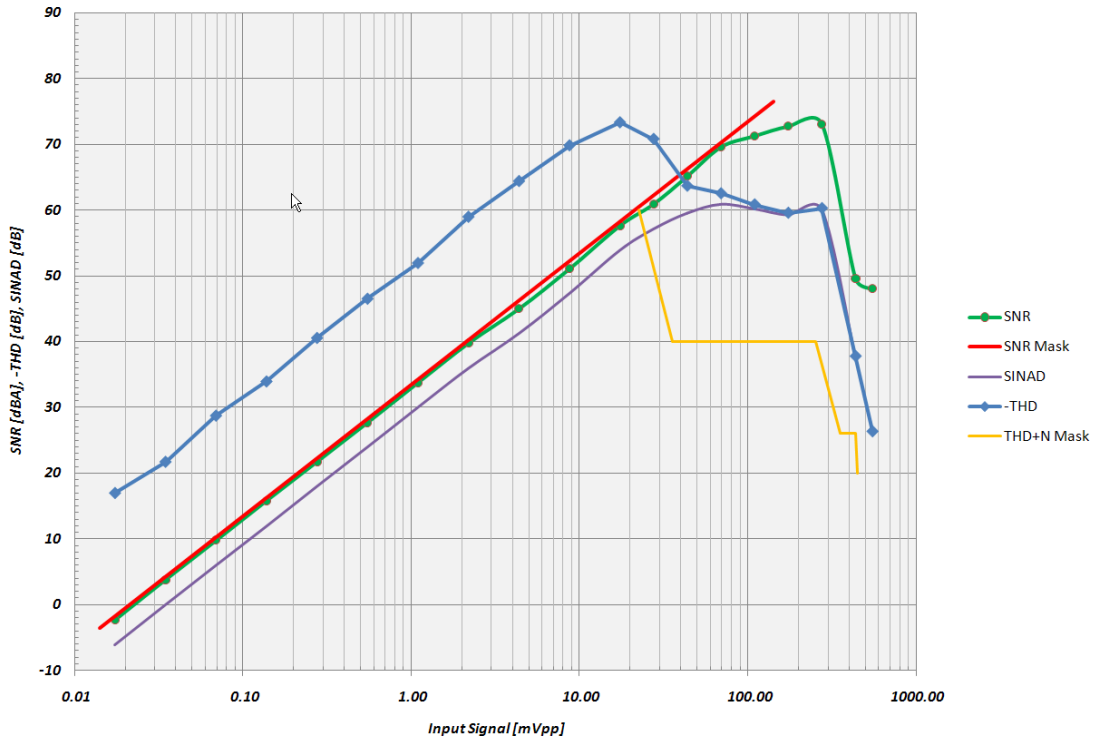

Figure 4. THD, SINDA, and SNR vs. Input Amplitude

# FAN3852

## TYPICAL PERFORMANCE CHARACTERISTICS (continued)

Unless otherwise specified, all limits are guaranteed for  $T_A = 25^\circ\text{C}$ ,  $V_{DD} = 1.8\text{ V}$ ,  $V_{IN} = 94\text{ dB (SPL)}$ ,  $f_{CLK} = 2.4\text{ MHz}$  and duty Cycle = 50%.

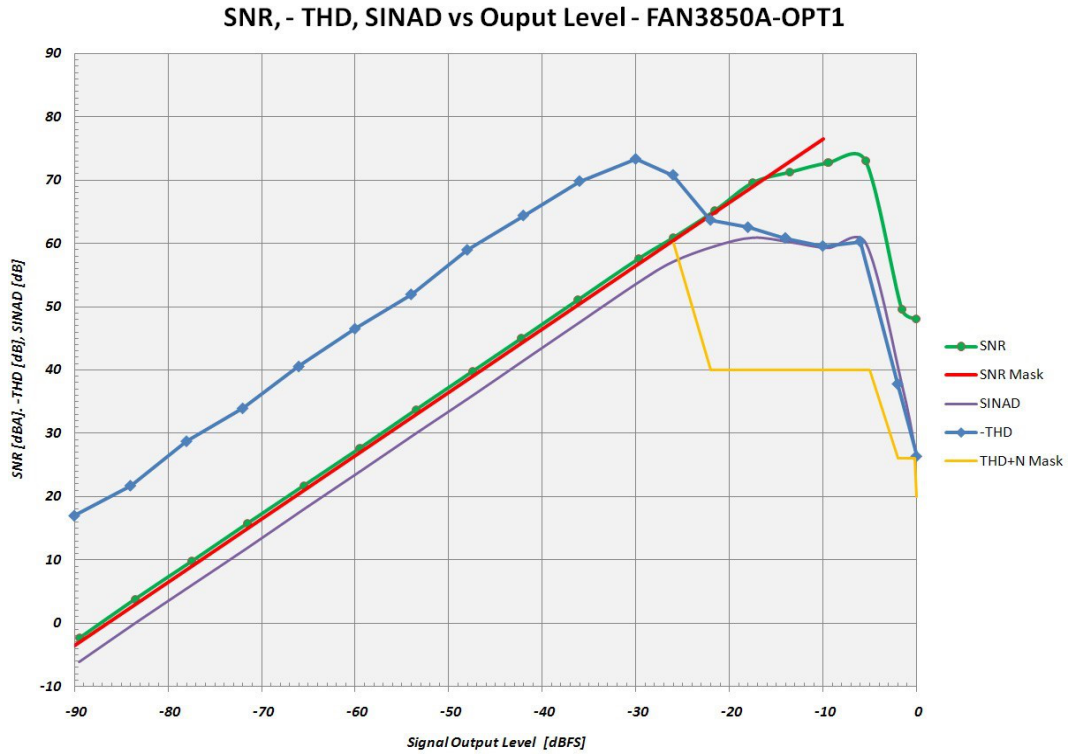

Figure 5. THD, SINAD and SNR vs. Output Level

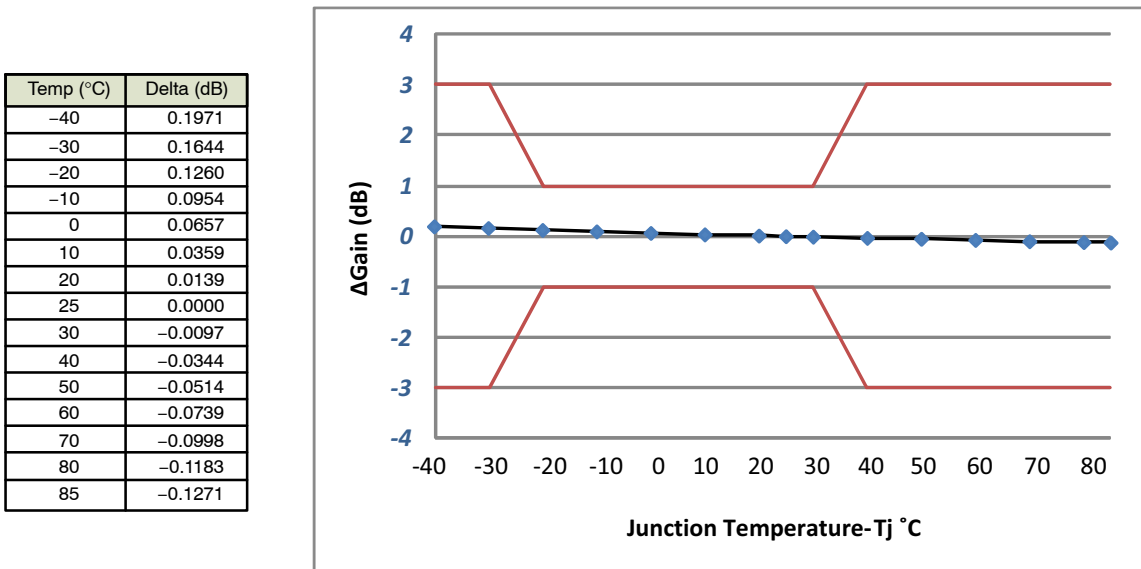

Figure 6.  $\Delta$  Gain vs. Temperature (Nominal Temperature =  $25^\circ\text{C}$ )

APPLICATIONS INFORMATION

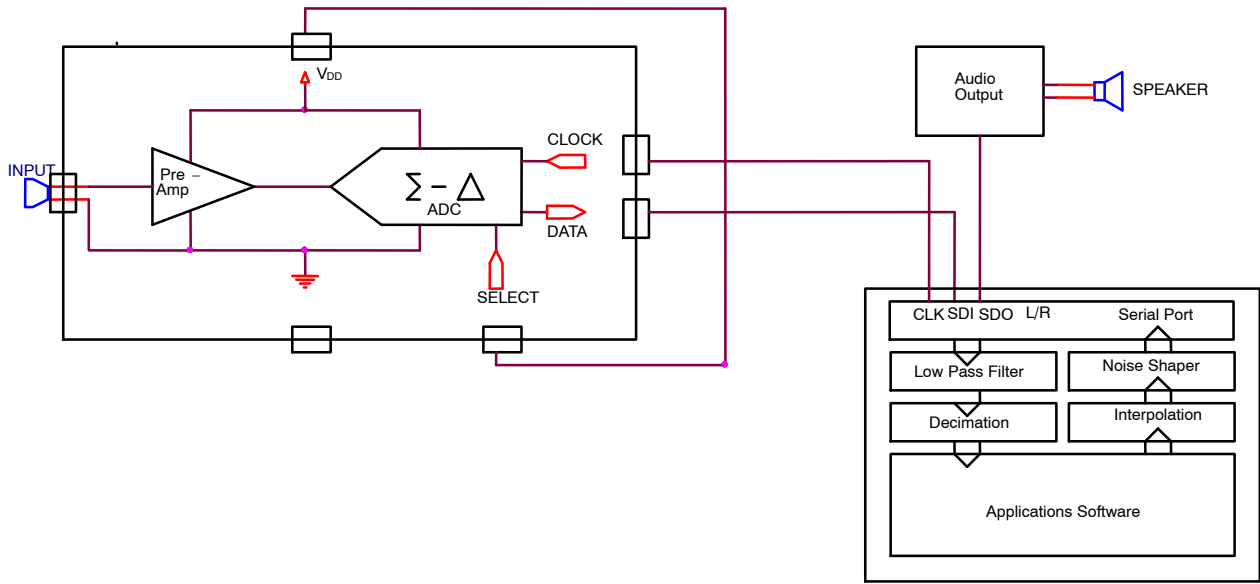

Figure 7. Mono Microphone Application Circuit

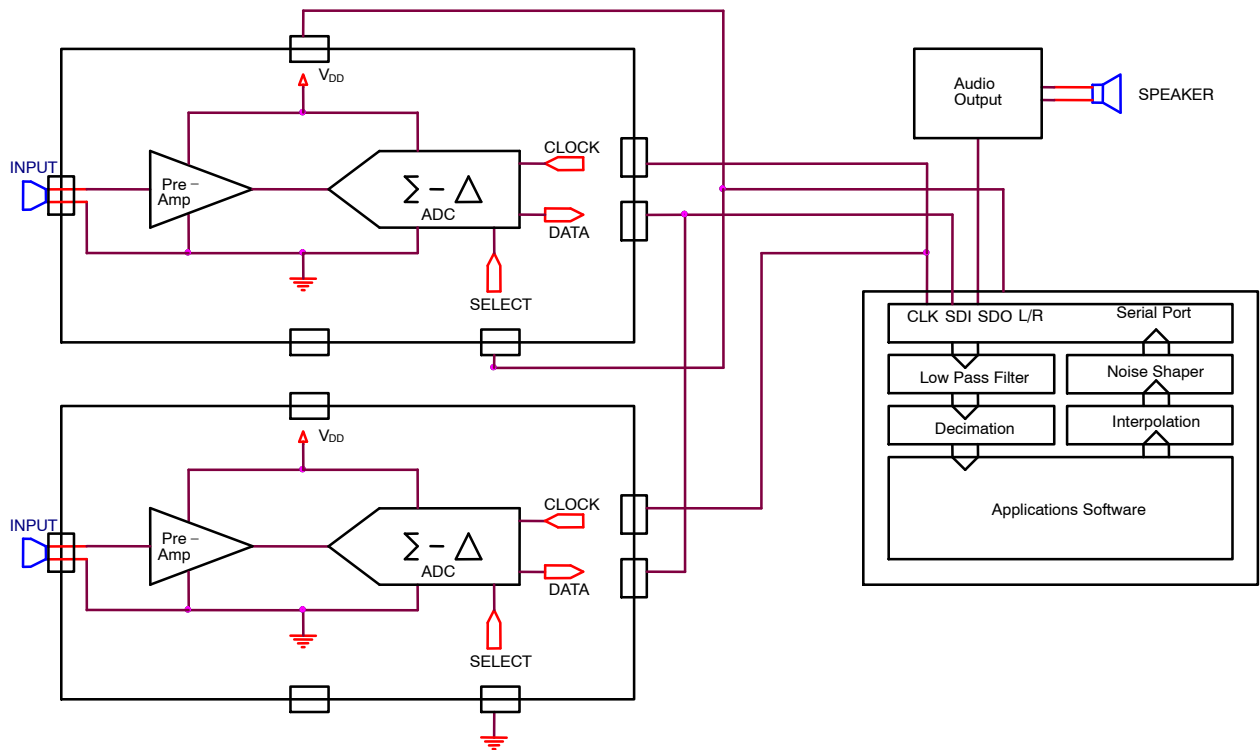
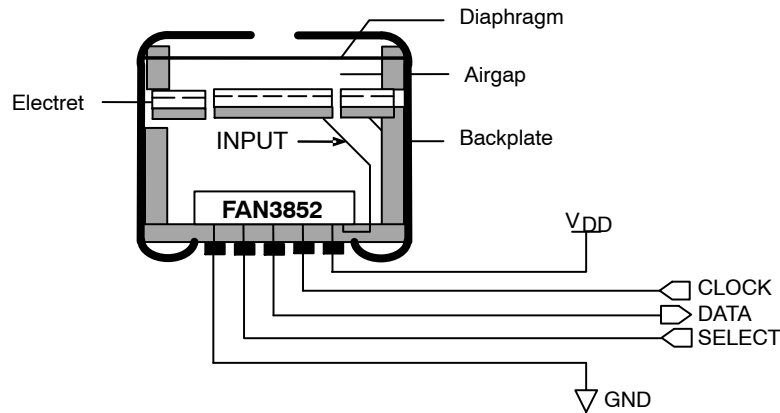

Figure 8. Stereo Microphone Application Circuit

# FAN3852

## APPLICATIONS INFORMATION (continued)



**Figure 9. MIC Element Drawing**

A 0.1  $\mu\text{F}$  decoupling capacitor is required for VDD. It can be located inside the microphone or on the PCB very close to the VDD pin.

Due to high input impedance, care should be taken to remove all flux used during the reflow soldering process.

A 100  $\Omega$  resistance is recommended on the clock output of the device driving the FAN3852 to minimize ringing and improve signal integrity.

For optimal PSR, route a trace to the VDD pin. Do not place a VDD plane under the device.

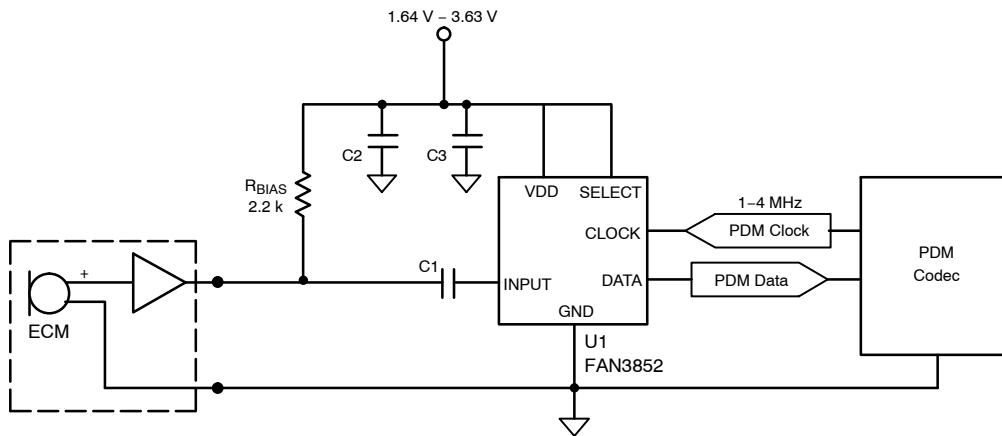

**Figure 10. Example Hardware Implementation**

**Table 7. RECOMMENDED COMPONENTS**

Ref Des	Qty	Description of Options	Package	Manufacturer	Mfg PIN
U1	1	FAN3852 Microphone Pre-Amplifier with Digital Output	WLCSP6	onsemi	FAN3852UC16X
C1	1	Input AC Coupling Capacitor; 1 nF/1000 pF, $\geq 6.3$ V, low-leakage	0402	Johansen Dielectrics	500R07W102KV4T
			0402	Murata	GCM155R71H102KA37D
			0603	Taiyo Yuden	UMK107SD102KA-T
C2	1	Primary VDD Decoupling Capacitor; 0.1 $\mu\text{F}$ , MLCC, $\geq 6.3$ V	0402	Samsung	CL05B104KO5NNNC
			0402	Yageo	CC0402KRX7R7BB104
			0603	AVX	06033C104KAT4A
C3	1	Optional VDD Decoupling Capacitor; 0.01 $\mu\text{F}$ , MLCC, $\geq 6.3$ V	0402	Samsung	CL05B103KB5VPNC
			0402	Murata	GCM155R71H103KA55J
			0603	Yageo	CC0603KRX7R7BB103

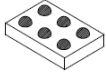

**WLCSP6 1.242x0.842x0.457**  
**CASE 567TS**  
**ISSUE A**

DATE 06 JUN 2019

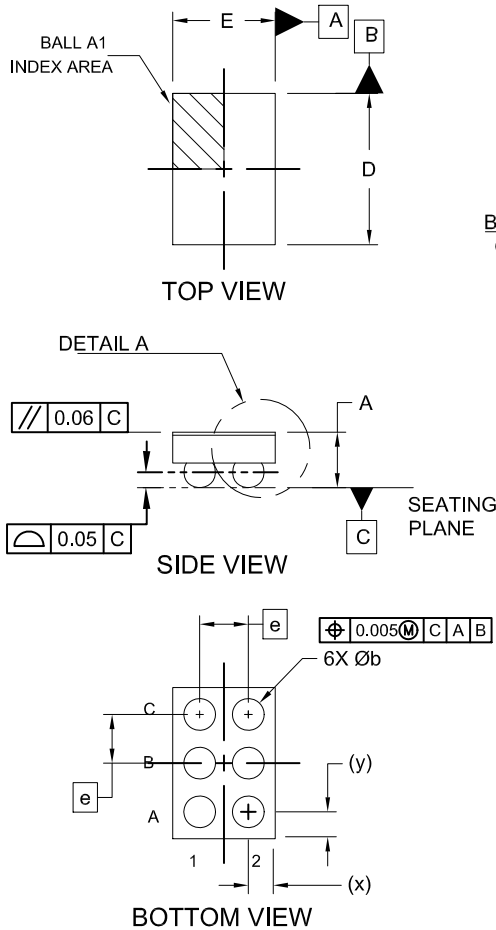

NOTES:

1. DIMENSIONING AND TOLERANCING PER ASME Y14.5M, 2009.
2. CONTROLLING DIMENSION: MILLIMETERS
3. DATUM C APPLIES TO THE SPHERICAL CROWN OF THE SOLDER BALLS

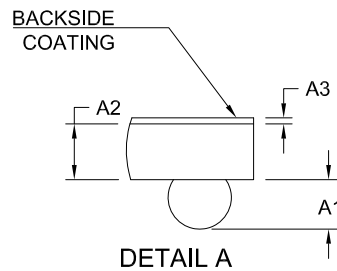

DIM	MILLIMETERS		
	MIN.	NOM.	MAX.
A	0.419	0.457	0.495
A1	0.183	0.203	0.223
A2	0.214	0.229	0.244
A3	0.022	0.025	0.028
b	0.24	0.26	0.28
D	1.212	1.242	1.272
E	0.812	0.842	0.872
e	0.40 BSC		
x	0.206	0.221	0.236
y	0.206	0.221	0.236

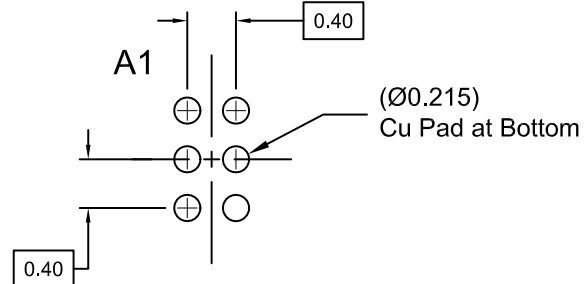

**RECOMMENDED MOUNTING FOOTPRINT\***  
**(NSMD PAD TYPE)**

\* For additional information on our Pb-Free strategy and soldering details, please download the ON Semiconductor Soldering and Mounting Techniques Reference Manual, SOLDERRM/D.

<b>DOCUMENT NUMBER:</b>	<b>98AON13367G</b>	Electronic versions are uncontrolled except when accessed directly from the Document Repository. Printed versions are uncontrolled except when stamped "CONTROLLED COPY" in red.
<b>DESCRIPTION:</b>	<b>WLCSP6 1.242x0.842x0.457</b>	<b>PAGE 1 OF 1</b>

onsemi and ONsemi are trademarks of Semiconductor Components Industries, LLC dba onsemi or its subsidiaries in the United States and/or other countries. onsemi reserves the right to make changes without further notice to any products herein. onsemi makes no warranty, representation or guarantee regarding the suitability of its products for any particular purpose, nor does onsemi assume any liability arising out of the application or use of any product or circuit, and specifically disclaims any and all liability, including without limitation special, consequential or incidental damages. onsemi does not convey any license under its patent rights nor the rights of others.

**onsemi**, **Onsemi**, and other names, marks, and brands are registered and/or common law trademarks of Semiconductor Components Industries, LLC dba "**onsemi**" or its affiliates and/or subsidiaries in the United States and/or other countries. **onsemi** owns the rights to a number of patents, trademarks, copyrights, trade secrets, and other intellectual property. A listing of **onsemi**'s product/patent coverage may be accessed at [www.onsemi.com/site/pdf/Patent-Marking.pdf](http://www.onsemi.com/site/pdf/Patent-Marking.pdf). **onsemi** reserves the right to make changes at any time to any products or information herein, without notice. The information herein is provided "as-is" and **onsemi** makes no warranty, representation or guarantee regarding the accuracy of the information, product features, availability, functionality, or suitability of its products for any particular purpose, nor does **onsemi** assume any liability arising out of the application or use of any product or circuit, and specifically disclaims any and all liability, including without limitation special, consequential or incidental damages. Buyer is responsible for its products and applications using **onsemi** products, including compliance with all laws, regulations and safety requirements or standards, regardless of any support or applications information provided by **onsemi**. "Typical" parameters which may be provided in **onsemi** data sheets and/or specifications can and do vary in different applications and actual performance may vary over time. All operating parameters, including "Typicals" must be validated for each customer application by customer's technical experts. **onsemi** does not convey any license under any of its intellectual property rights nor the rights of others. **onsemi** products are not designed, intended, or authorized for use as a critical component in life support systems or any FDA Class 3 medical devices or medical devices with a same or similar classification in a foreign jurisdiction or any devices intended for implantation in the human body. Should Buyer purchase or use **onsemi** products for any such unintended or unauthorized application, Buyer shall indemnify and hold **onsemi** and its officers, employees, subsidiaries, affiliates, and distributors harmless against all claims, costs, damages, and expenses, and reasonable attorney fees arising out of, directly or indirectly, any claim of personal injury or death associated with such unintended or unauthorized use, even if such claim alleges that **onsemi** was negligent regarding the design or manufacture of the part. **onsemi** is an Equal Opportunity/Affirmative Action Employer. This literature is subject to all applicable copyright laws and is not for resale in any manner.

## ADDITIONAL INFORMATION

### TECHNICAL PUBLICATIONS:

Technical Library: [www.onsemi.com/design/resources/technical-documentation](http://www.onsemi.com/design/resources/technical-documentation)  
onsemi Website: [www.onsemi.com](http://www.onsemi.com)

### ONLINE SUPPORT: [www.onsemi.com/support](http://www.onsemi.com/support)

For additional information, please contact your local Sales Representative at [www.onsemi.com/support/sales](http://www.onsemi.com/support/sales)